

### Description

The SX8724 is a data acquisition system based on Semtech's low power ZoomingADC™ technology. It directly connects most types of miniature sensors with a general purpose microcontroller.

With 3 differential inputs, it can adapt to multiple sensor systems. Its digital outputs are used to bias or reset the sensing elements.

### Applications

- Industrial pressure sensing
- Industrial temperature sensing
- Barometer
- Compass

### Features

- Up to 16-bit differential data acquisition
- Programmable gain: (1/12 to 1000)
- Sensor offset compensation up to 15 times full scale of input signal
- 3 differential or 6 single-ended signal inputs
- Programmable Resolution versus Speed versus Supply current
- 4 digital outputs to bias Sensors
- Internal or external voltage reference
- Internal time base
- Low-power (250 uA for 16b @ 500 S/s)
- I2C interface

### Ordering Information

Device	Package
SX8724E082TRT	MLPQ-16 4x4

- 1) Available in tape and reel only
- 2) Lead free, WEEE and RoHS compliant.

### Functional Block Diagram

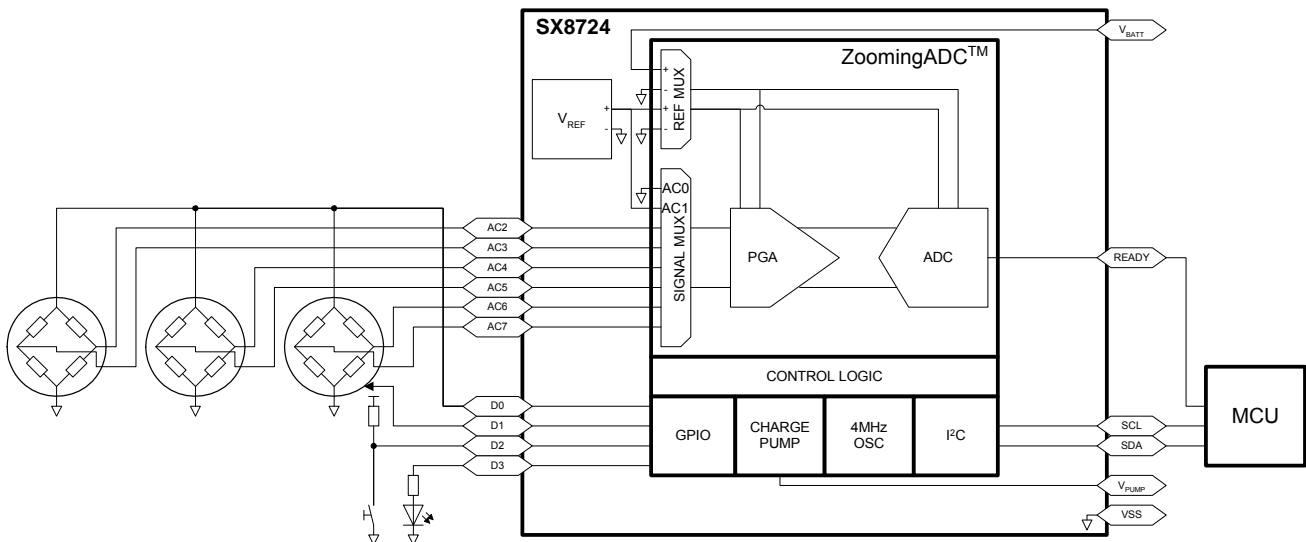

## Table of Contents

Description.....	1
Applications.....	1
Features .....	1
Ordering Information .....	1
Functional Block Diagram .....	1
Absolute Maximum Ratings .....	4
Electrical Characteristics .....	5
ZoomingADC Specifications.....	6
Timing Characteristics .....	8
I <sup>2</sup> C Timing Waveforms .....	8
Pin Configuration .....	9
Marking Information.....	9
Pin Description .....	9
<b>Circuit Description .....</b>	<b>10</b>
<i>General Description.....</i>	10
<i>Block Diagram.....</i>	10
<i>VREF.....</i>	10
<i>GPIO .....</i>	11
<i>Charge Pump.....</i>	12
<i>RC Oscillator .....</i>	13
<i>I<sup>2</sup>C.....</i>	14
<i>I<sup>2</sup>C Communication Format.....</i>	14
<i>I<sup>2</sup>C Address .....</i>	14
<b>ZoomingADC .....</b>	<b>15</b>
<i>Features .....</i>	15
<i>Overview .....</i>	15
<i>ZADC Description.....</i>	15
Acquisition Chain.....	15
Registers .....	17
<i>ZADC Detailed Functionality Description.....</i>	18
Continuous-Time vs. On-Request.....	18
Input Multiplexers .....	19
Programmable Gain Amplifiers .....	20
PGA & ADC Enabling.....	21
PGA1 .....	21
PGA2 .....	21
PGA3.....	21
ADC Characteristics.....	22
Conversion Sequence.....	22
Over-Sampling Frequency .....	22
Over-Sampling Ratio.....	23
Elementary Conversions .....	23
Resolution .....	24
Conversion Time and Throughput.....	25
Output Code Format.....	26
Power Saving Modes .....	27
<i>Registers Map .....</i>	28
<i>Registers Descriptions .....</i>	28
<i>RC Register.....</i>	28
<i>GPIO Registers .....</i>	29
<i>ZADC Registers .....</i>	30
<i>Mode Register .....</i>	31
Optional Operating Modes: External Voltage Reference Option .....	32
<b>Application Hints.....</b>	<b>33</b>
<i>Recommended Operation Mode and Registers Settings.....</i>	33
Operation Mode.....	33

Registers Settings .....	33
Schematic.....	34
<i>Input Impedance</i> .....	35
Switched Capacitor Principle .....	36
<i>PGA Settling or Input Channel Modifications</i> .....	37
<i>PGA Gain &amp; Offset, Linearity and Noise</i> .....	37
<i>Frequency Response</i> .....	38
<i>Power Reduction</i> .....	39
<i>Recommended Design for Other I2C Devices Connection</i> .....	39
<b>Typical Performance</b> .....	<b>40</b>
<i>Linearity</i> .....	40
Integral Non-Linearity .....	40
Differential Non-Linearity.....	43
<i>Noise</i> .....	44
<i>Gain Error and Offset Error</i> .....	46
<i>Power Consumption</i> .....	47
<b>PCB Layout Considerations</b> .....	<b>49</b>
<b>How to Evaluate</b> .....	<b>49</b>
<b>Package Outline Drawing: MLPQ-16 4x4</b> .....	<b>50</b>
<b>Land Pattern Drawing: MLPQ-16 4x4</b> .....	<b>51</b>
<b>Tape and Reel Specification</b> .....	<b>52</b>

**Absolute Maximum Ratings**

Exceeding the specifications below may result in permanent damage to the device or device malfunction. Operation outside the parameters specified in the Electrical Characteristics section is not implied.

Parameter	Symbol	Comments / Conditions	Min	Max	Unit
Power supply	V <sub>BATT</sub>		V <sub>SS</sub> - 0.3	5.7	V
Storage temperature	T <sub>STORE</sub>		-55	150	°C
Temperature under bias	T <sub>BIAS</sub>		-40	140	°C
Max sensor common mode	V <sub>VR_P</sub>		V <sub>SS</sub> - 300	V <sub>BATT</sub> +300	mV
	V <sub>VR_N</sub>				
Input voltage			V <sub>SS</sub> - 300	V <sub>BATT</sub> +300	mV
Peak reflow temperature	T <sub>PKG</sub>			260	°C

**Notes:** This device is ESD sensitive. Use of standard ESD handling precautions is required.

**Electrical Characteristics**

All values are valid within the operating conditions unless otherwise specified.

Parameter	Symbol	Comments / Conditions	Min	Typ	Max	Unit
<b>Operating conditions</b>						
Power supply	$V_{BATT}$		2.4		5.5	V
Operating temperature	$T_{OP}$		-40		125	° C
<b>Current consumption</b>						
Active current, @ 30 °C, 5.5 V	$I_{OP}$	16 b @ 250 Sample/s ADC, $f_s = 125$ kHz		250	300	$\mu$ A
		16 b @ 1 kSample/s PGA3 + ADC, $f_s = 500$ kHz		700	800	
		16 b + gain 1000 @ 1 kSample/s PGA3,2,1 + ADC, $f_s = 500$ kHz		1000	1200	
Active current, @ 30 °C, 3.3 V	$I_{OP}$	16 b @ 250 Sample/s PGA3 + ADC, $f_s = 125$ kHz		150		$\mu$ A
		16 b @ 1 kSample/s PGA3 + ADC, $f_s = 500$ kHz		300		
		16 b + gain 1000 @ 1 kSample/s PGA3,2,1 + ADC, $f_s = 500$ kHz		850		
Sleep current	$I_{sleep}$	@ 30 °C		75	200	nA
		up to 85 °C		100		
		@125 °C		150		
<b>Time base</b>						
Max ADC over-sampling frequency	$F_{Smax}$	@ 25 °C	450	500	550	kHz
Min ADC over-sampling frequency	$F_{Smin}$	@ 25 °C	56.25	62.5	68.75	kHz
<b>Digital I/O</b>						
Input logic high	$V_{IH}$		0.7			$V_{BATT}$
Input logic low	$V_{IL}$				0.3	$V_{BATT}$
Output logic high	$V_{OH}$	$I_{OH} < 4$ mA			$V_{BATT}-0.4$	V
Output logic low	$V_{OL}$	$I_{OL} < 4$ mA	0.4			V
<b>VREF: Internal Bandgap Reference</b>						
Absolute output voltage		$V_{BATT} > 3$ V	1.19	1.22	1.25	V
Variation over Temperature		$V_{BATT} > 3$ V, ref to 25° C	-1		+1	%
Total Output Noise		$V_{BATT} > 3$ V, rms, broadband			1	mV

**ADVANCED COMMUNICATIONS & SENSING**
**ZoomingADC Specifications**

Unless otherwise specified: Temperature  $T_A = +25^\circ\text{C}$ ,  $V_{DD} = +5\text{V}$ ,  $\text{GND} = 0\text{V}$ ,  $V_{REF\_ADC} = +5\text{V}$ ,  $V_{IN} = 0\text{V}$ , over-sampling frequency  $f_s = 250\text{kHz}$ , *PGA3 on with Gain = 1, PGA1&PGA2 off*, offsets  $\text{GDOff}_2 = \text{GDOff}_3 = 0$ . Power operation: normal ( $\text{IB\_AMP\_ADC}[1:0] = \text{IB\_AMP\_PGA}[1:0] = '01'$ ). For resolution  $n = 12$  bits:  $\text{OSR} = 32$  and  $N_{ELCONV} = 4$ . For resolution  $n = 16$  bits:  $\text{OSR} = 512$  and  $N_{ELCONV} = 2$ . Bandgap chopped at  $N_{ELCONV}$  rate.

Parameter	Symbol	Comments / Conditions	Min	Typ	Max	Unit
<b>Analog Input</b>						
Differential Input Voltage Ranges $V_{IN} = (V_{INP} - V_{INN})$		Gain = 1, OSR = 32 (Note 1)	-2.42		2.42	V
		Gain = 100, OSR = 32	-24.2		24.2	mV
		Gain = 1000, OSR = 32	-2.42		2.42	mV
Reference Voltage Range $V_{REF\_ADC} = (V_{REFP} - V_{REFN})$					$V_{DD}$	V
<b>Programmable Gain Amplifier (PGA)</b>						
Total PGA Gain	$\text{GD}_{TOT}$	(Note 1)	1/12		1000	V/V
PGA1 Gain	$\text{GD}_1$	See Table 5	1		10	V/V
PGA2 Gain	$\text{GD}_2$	See Table 6	1		10	V/V
PGA3 Gain	$\text{GD}_3$	Step = 1/12 V/V, See Table 8	0		127/12	V/V
Gain Setting Precision (each stage)			-3	$\pm 0.5$	3	%
Gain Temperature Dependence				$\pm 5$		ppm/ $^\circ\text{C}$
PGA2 Offset	$\text{GDoff}_2$	Step = 0.2 V/V, See Table 7	-1		1	V/V
PGA3 Offset	$\text{GDoff}_3$	Step = 1/12 V/V, See Table 9	-63/12		63/12	V/V
Offset Setting Precision (PGA2 or 3)		(Note 2)	-3	$\pm 0.5$	3	%
Offset Temperature Dependence				$\pm 5$		ppm/ $^\circ\text{C}$
Input Impedance PGA1		Gain = 1 (Note 3)	1500			k $\Omega$
		Gain = 10 (Note 3)	150			k $\Omega$
Input Impedance PGA2, PGA3		Maximal gain (Note 3)	150			k $\Omega$
Output RMS noise		PGA1 (Note 4)		205		$\mu\text{V}$
		PGA2 (Note 5)		340		$\mu\text{V}$
		PGA3 (Note 6)		365		$\mu\text{V}$
<b>ADC Static Performance</b>						
Resolution, n		(Note 7)	6		16	Bits
No Missing Codes		(Note 8)			16	Bits
Gain Error		(Note 9)		$\pm 0.15$		%
Offset Error		n = 16 bits (Note 10)		$\pm 1$		%
				$\pm 1$		LSB
Integral Non-Linearity, INL		n = 12 Bits (Note 11)		$\pm 0.6$		LSB
		n = 16 Bits (Note 11)		$\pm 1.5$		LSB
Differential Non-Linearity, DNL		n = 12 Bits (Note 12)		$\pm 0.5$		LSB
		n = 16 Bits (Note 12)		$\pm 0.5$		LSB
Common Mode input range			$V_{SS}-0.3$		$V_{BATT}+0.3$	V
Power Supply Rejection Ratio	PSRR	VDD = 5V $\pm$ 0.3V (Note 13)		78		dB
		VDD = 3V $\pm$ 0.3V (Note 13)		72		dB
<b>ADC Dynamic Performance</b>						
Conversion Time	$T_{CONV}$	n = 12 bits (Note 14)	133			cycles/ $f_s$
		n = 16 bits (Note 14)	1027			cycles/ $f_s$
Throughput Rate (Continuous Mode)	$1/T_{CONV}$	n = 12 bits, $f_s = 250\text{kHz}$		1.88		kSps
		n = 16 bits, $f_s = 250\text{kHz}$		0.485		kSps
Nbr of Initialization Cycles	$N_{INIT}$		0		2	cycles

**ADVANCED COMMUNICATIONS & SENSING**

Parameter	Symbol	Comments / Conditions	Min	Typ	Max	Unit
Nbr of End Conversion Cycles	$N_{END}$		0		5	cycles
PGA Stabilization Delay		(Note 15)		OSR		cycles
<b>ADC Digital Output</b>						
Output Data Coding		Binary Two's Complement See Table 15 and Table 16				
<b>Power Supply</b>						
Voltage Supply Range	$V_{DD}$		2.4	5	5.5	V
Analog Quiescent Current		Only ZoomingADC				
Total Consumption	$I_Q$	$V_{DD} = 5V/3V$		800/675		$\mu A$
ADC Only Consumption		$V_{DD} = 5V/3V$		260/190		$\mu A$
PGA1 Consumption		$V_{DD} = 5V/3V$		190/170		$\mu A$
PGA2 Consumption		$V_{DD} = 5V/3V$		150/135		$\mu A$
PGA3 Consumption		$V_{DD} = 5V/3V$		200/180		$\mu A$
Analog Power Dissipation		All PGAs & ADC Active				
Normal Power Mode		$V_{DD} = 5V/3V$ (Note 16)		4.0/2.0		mW
3/4 Power Reduction Mode		$V_{DD} = 5V/3V$ (Note 17)		3.2/1.6		mW
1/2 Power Reduction Mode		$V_{DD} = 5V/3V$ (Note 18)		2.4/1.1		mW
1/4 Power Reduction Mode		$V_{DD} = 5V/3V$ (Note 19)		1.5/0.7		mW
<b>Temperature</b>						
Operating Range			-40		125	$^{\circ}C$

**Notes:**

- (1) Gain defined as overall PGA gain  $GD_{TOT} = GD_1 \cdot GD_2 \cdot GD_3$ . Maximum input voltage is given by:  $V_{IN,MAX} = \pm(V_{REF,ADC}/2) \cdot (OSR/OSR+1)$ .
- (2) Offset due to tolerance on  $GDOFF_2$  or  $GDOFF_3$  setting. For small intrinsic offset, use only ADC and PGA1.
- (3) Measured with block connected to inputs through AMUX block. Normalized input sampling frequency for input impedance is  $f_S = 500kHz$ . This figure must be multiplied by 2 for  $f_S = 250kHz$ , 4 for  $f_S = 125kHz$ . Input impedance is proportional to  $1/f_S$ .
- (4) Figure independent on PGA1 gain and sampling frequency  $f_S$ .
- (5) Figure independent on PGA2 gain and sampling frequency  $f_S$ .
- (6) Figure independent on PGA3 gain and sampling frequency  $f_S$ .
- (7) Resolution is given by  $n = 2 \cdot \log_2(OSR) + \log_2(N_{ELCONV})$ . OSR can be set between 8 and 1024, in powers of 2.  $N_{ELCONV}$  can be set to 1, 2, 4 or 8.
- (8) If a ramp signal is applied to the input, all digital codes appear in the resulting ADC output data.
- (9) Gain error is defined as the amount of deviation between the ideal (theoretical) transfer function and the measured transfer function (with the offset error removed).
- (10) Offset error is defined as the output code error for a zero volt input (ideally, output code = 0). For  $\pm 1$  LSB offset,  $N_{ELCONV}$  must be  $\geq 2$ .
- (11) INL defined as the deviation of the DC transfer curve of each individual code from the best-fit straight line. This specification holds over the full scale. (For 16 bits INL set PGA3 on).
- (12) DNL is defined as the difference (in LSB) between the ideal (1 LSB) and measured code transitions for successive codes.
- (13) Figures for Gains = 1 to 100. PSRR is defined as the amount of change in the ADC output value as the power supply voltage changes.
- (14) Conversion time is given by:  $T_{CONV} = (N_{ELCONV} \cdot (OSR + 1) + 1) / f_S$ . OSR can be set between 8 and 1024, in powers of 2.  $N_{ELCONV}$  can be set to 1, 2, 4 or 8.
- (15) PGAs are reset after each writing operation to registers **RegACCfg1-5**. The ADC must be started after a PGA or inputs common-mode stabilization delay. This is done by writing bit Start several cycles after PGA settings modification or channel switching. Delay between PGA start or input channel switching and ADC start should be equivalent to OSR (between 8 and 1024) number of cycles. This delay does not apply to conversions made without the PGAs.
- (16) Nominal (maximum) bias currents in PGAs and ADC, i.e.  $IB\_AMP\_PGA[1:0] = '11'$  and  $IB\_AMP\_ADC[1:0] = '11'$ .
- (17) Bias currents in PGAs and ADC set to 3/4 of nominal values, i.e.  $IB\_AMP\_PGA[1:0] = '10'$ ,  $IB\_AMP\_ADC[1:0] = '10'$ .
- (18) Bias currents in PGAs and ADC set to 1/2 of nominal values, i.e.  $IB\_AMP\_PGA[1:0] = '01'$ ,  $IB\_AMP\_ADC[1:0] = '01'$ .
- (19) Bias currents in PGAs and ADC set to 1/4 of nominal values, i.e.  $IB\_AMP\_PGA[1:0] = '00'$ ,  $IB\_AMP\_ADC[1:0] = '00'$ .

**Timing Characteristics**

Parameter	Symbol	Comments / Conditions	Min	Typ	Max	Unit
<b>Interrupt (Ready) timing specification</b>						
READY pulse width (2)	$t_{IRQ}$			1		$1/F_s$
<b>I2C timing specifications(1)</b>						
SCL clock frequency	$f_{SCL}$		0		400	kHz
SCL low period	$t_{LOW}$		1.3			$\mu s$
SCL high period	$t_{HIGH}$		0.6			$\mu s$
Data setup time	$t_{SU,DAT}$		100			ns
Data hold time	$t_{HD,DAT}$		0			ns
Repeated start setup time	$t_{SU,STA}$		0.6			$\mu s$
Start condition hold time	$t_{HD,STA}$		0.6			$\mu s$
Stop condition hold time	$t_{SU,STO}$		0.6			$\mu s$
Bus free time between stop and start	$t_{BUF}$		1.3			$\mu s$
Input glitch suppression	$t_{SP}$		50			ns

**Notes:**

- (1) All timing specifications are referred to VILmin and VIHmax voltage levels defined for the SCL and SDA pins.
- (2) The READY pulse indicates End of Conversion. This is a Low going pulse of duration equal to one cycle of the ADC sampling rate.

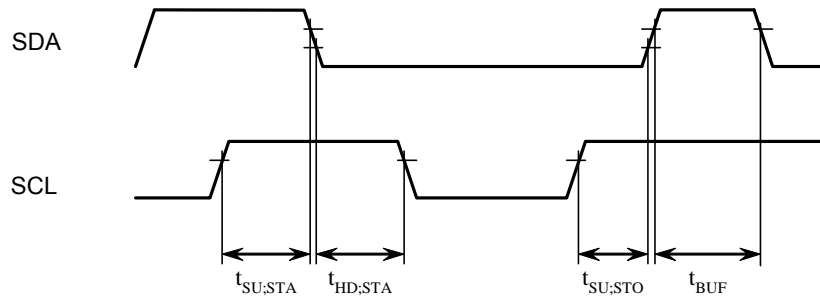
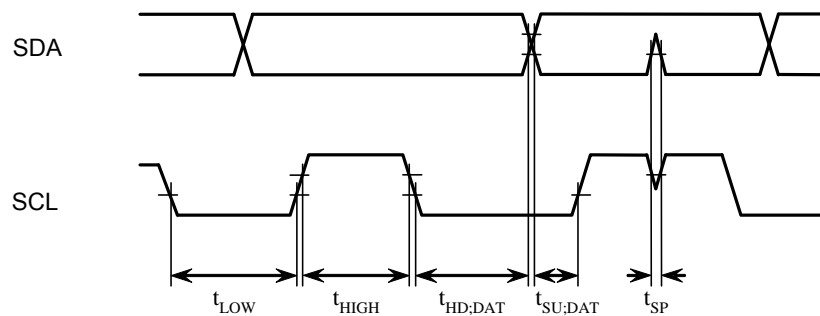
**I<sup>2</sup>C Timing Waveforms**

**Figure 1 - I<sup>2</sup>C Start and Stop timings**

**Figure 2 - I<sup>2</sup>C Data timings**

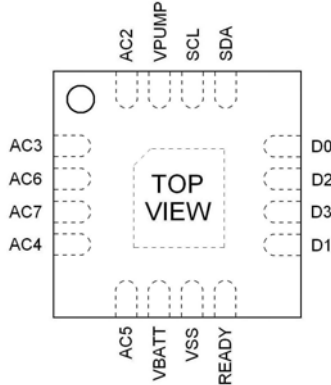

### Pin Configuration



### Marking Information



yyww = Date code  
xxxx = Semtech lot number

### Pin Description

Pin	Name	Type	Function
1	AC <sub>3</sub>	Analog Input	Differential sensor input in conjunction with AC <sub>2</sub>
2	AC <sub>6</sub>	Analog Input	Differential sensor input in conjunction with AC <sub>7</sub>
3	AC <sub>7</sub>	Analog Input	Differential sensor input in conjunction with AC <sub>6</sub>
4	AC <sub>4</sub>	Analog Input	Differential sensor input in conjunction with AC <sub>5</sub>
5	AC <sub>5</sub>	Analog Input	Differential sensor input in conjunction with AC <sub>4</sub>
6	V <sub>BATT</sub>	Power Input	2.4V to 5.5V power supply
7	V <sub>SS</sub>	Power Input	Chip Ground
8	READY	Digital Output	Conversion complete flag.
9	D <sub>1</sub>	Digital IO + analog	Digital output sensor drive (V <sub>BATT</sub> or V <sub>SS</sub> ) V <sub>REF</sub> Input in optional operating mode
10	D <sub>3</sub>	Digital IO	Digital output sensor drive (V <sub>BATT</sub> or V <sub>SS</sub> )
11	D <sub>2</sub>	Digital IO	Digital output sensor drive (V <sub>BATT</sub> or V <sub>SS</sub> )
12	D <sub>0</sub>	Digital IO + analog	Digital output sensor drive (V <sub>BATT</sub> or V <sub>SS</sub> ) V <sub>REF</sub> Output in optional operating mode
13	SDA	Digital IO	I <sup>2</sup> C Data
14	SCL	Digital IO	I <sup>2</sup> C Clock. Up to 400 kHz.
15	V <sub>PUMP</sub>	Power IO	Charge pump output. Raises ADC supply above V <sub>BATT</sub> if V <sub>BATT</sub> supply is too low. Recommended range for capacitor is 1nF to 10 nF. Connect the capacitor to GND.
16	AC <sub>2</sub>	Analog Input	Differential sensor input in conjunction with AC <sub>3</sub>
17	V <sub>SS</sub>	Power Input	Bottom ground pad (1)

**Notes:**

(1) This pin is internally connected to V<sub>SS</sub>. It should also be connected to V<sub>SS</sub> on PCB to reduce noise and improve thermal behavior.

## Circuit Description

### General Description

The SX8724 is a complete low-power acquisition path with programmable gain, acquisition speed and resolution.

### Block Diagram

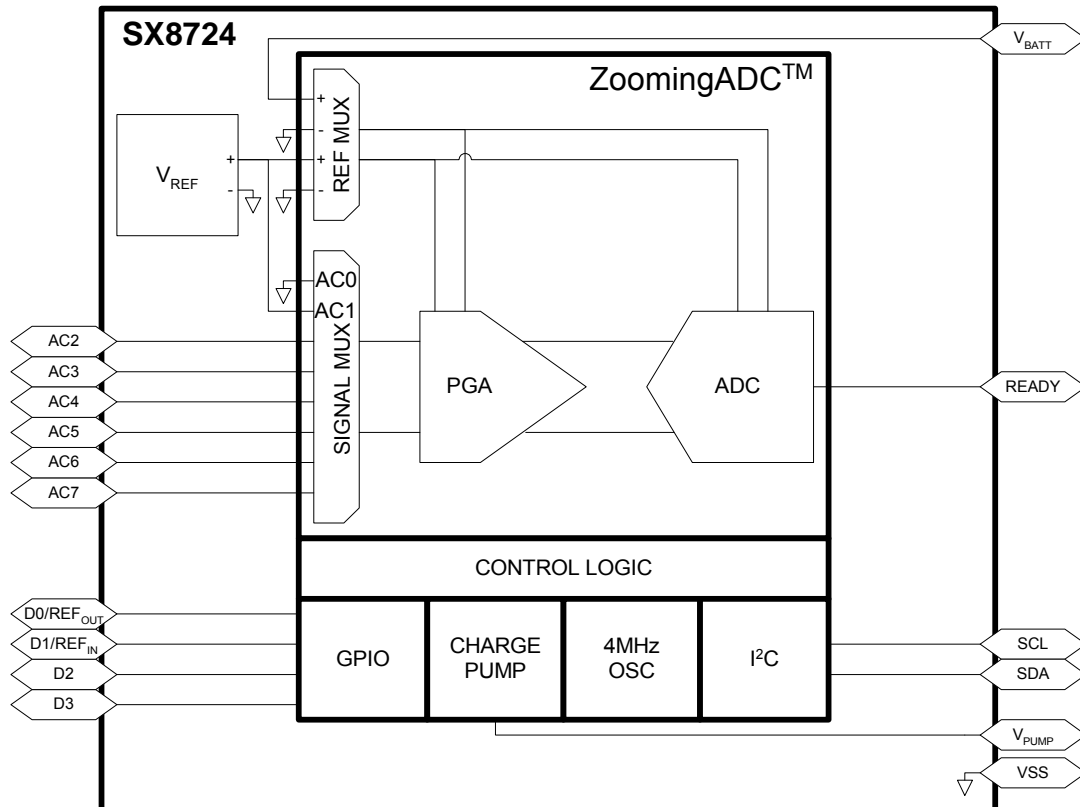

**Figure 3 - SX8724 Block Diagram**

### V<sub>REF</sub>

The internally generated  $V_{REF}$  is a trimmed bandgap reference with a nominal value of 1.22V that provides a stable voltage reference for the ZoomingADC.

This reference voltage is directly connected to one of the ZoomingADC reference multiplexer inputs.

The bandgap voltage stability is only guaranteed for  $V_{BATT}$  voltages of 3V and above. As  $V_{BATT}$  drops down to 2.4V, the bandgap voltage could reduce by up to 50mV.

The bandgap has relatively weak output drive so it is recommended that if the bandgap is required as a signal input then PGA1 must be enabled with Gain = 1.

## GPIO

The GPIO block is a multipurpose 4 bit input/output port. In addition to digital behavior, D0 and D1 pins can be programmed as analog pins in order to be used as output (reference voltage monitoring) and input for an external reference voltage (For further details see Figure 14, Figure 15, Figure 16 and Figure 17). Each port terminal can be individually selected as digital input or output.

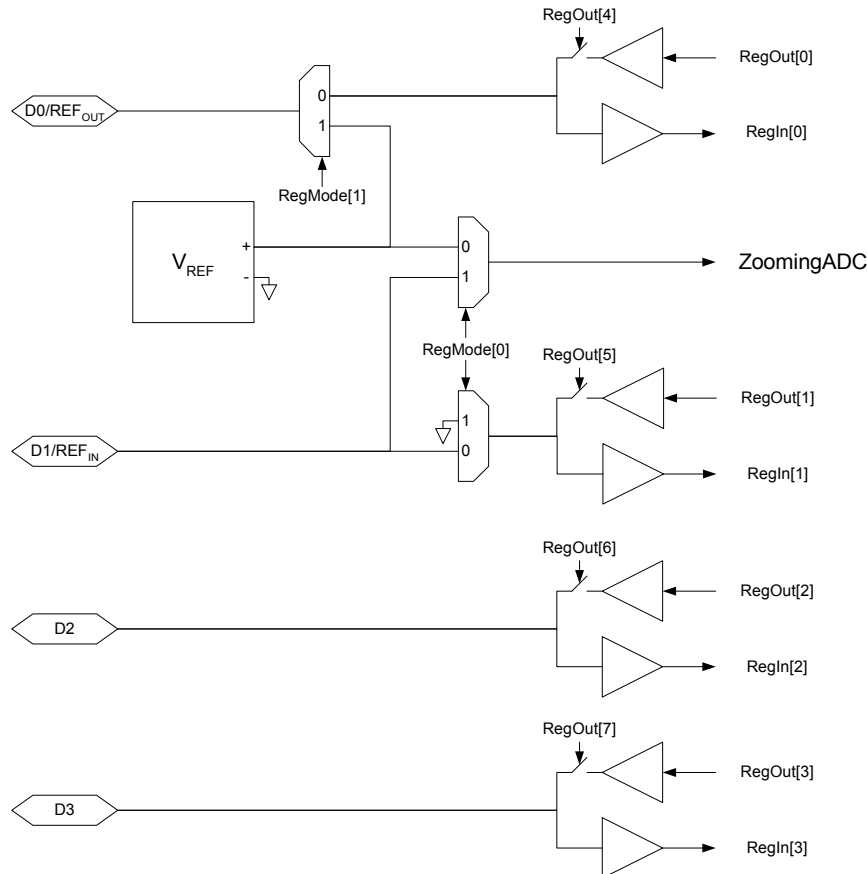

**Figure 4 - GPIO Block Diagram**

The direction of each bit within the GPIO block (input only or input/output) can be individually set using the 4 MSB bits of the **RegOut** register. If  $D[x]_{DIR} = 1$ , both the input and output buffer are active on the corresponding GPIO block pin. If  $D[x]_{DIR} = 0$ , the corresponding GPIO block pin is an input only and the output buffer is in high impedance. After power on reset the GPIO block pins are in input/output mode ( $D[x]_{DIR}$  are reset to 1)

The input values of GPIO block are available in **RegIn** register (read only). Reading is always direct – there is no debounce function in the GPIO block. In case of possible noise on input signals, an external hardware filter has to be realized. The input buffer is also active when the GPIO block is defined as output and the effective value on the pin can be read back.

Data stored in the 4 LSB bits of **RegOut** register are outputted at GPIO block if  $D[x]_{DIR} = 1$ . The default values after power on reset is low (0).

The digital pins are able to deliver a driving current up to 8 mA.

When the bits  $VREF\_D0\_OUT$  and  $VREF\_D1\_IN$  in the **RegMode** register are set to 1 the D0 and D1 pins digital behavior are automatically bypassed in order to either input or output the voltage reference signals.

### Charge Pump

This block generates a supply voltage able to power the analog switch drive levels on the chip.

The minimum acceptable switch supply is 3V which means that if  $V_{BATT}$  drops below 3V then the block should be activated to generate a voltage of 3V or above. If  $V_{BATT}$  is greater than 3V then  $V_{BATT}$  may be switched straight through to the  $V_{PUMP}$  output.

If control input bit `MULT_FORCE_OFF` = 1 in **RegMode** register then the charge pump is disabled and  $V_{BATT}$  is permanently connected to  $V_{PUMP}$ .

If control input bit `MULT_FORCE_ON` = 1 in **RegMode** register then the charge pump is permanently enabled. This overrides `MULT_FORCE_OFF` bit in **RegMode** register.

If `MULT_FORCE_ON` = 0 and `MULT_FORCE_OFF` = 0 bits in **RegMode** register then the charge pump will start if  $V_{BATT}$  drops below 3V, otherwise  $V_{BATT}$  will be switched directly through to  $V_{PUMP}$ .

These controls are supplied to give the user the option of fixing the charge pump state to avoid it turning off and on when  $V_{BATT}$  is close to 3V.

The cell will use the on-chip bandgap reference and comparator to detect when  $V_{BATT}$  is too low. When activated, the block will use the charge pump to boost the  $V_{BATT}$  voltage to above 3V but with diode limiting to ensure that the generated voltage never exceeds 0.7V above  $V_{BATT}$ .

An external capacitor is required on  $V_{PUMP}$  whenever the power supply is supposed to be less or drop below 3V. This capacitor should be large enough to ensure that generated voltage is smooth enough to avoid affecting conversion accuracy but not so large that it gives an unacceptable settling time. A recommended value is around 2.2nF.

The block will also indicate when the pumped output voltage is sufficiently high to allow ADC conversions to be started. This will be a simple comparison which will give a ready signal when the  $V_{PUMP}$  output is 3V or above.

### RC Oscillator

This block provides the master clock reference for the chip. It produces a clock at 4 MHz which is divided internally in order to generate the clock sources needed by the other blocks.

The oscillator technique is a low power relaxation design and it is designed to vary as little as possible over temperature and supply voltage.

This oscillator is trimmed at manufacture chip test.

The RC oscillator will start up after a chip reset to allow the trimming values to be read and calibration registers and I<sup>2</sup>C address set to their programmed values. Once this has been done, the oscillator will be shut down and the chip will enter a sleep state while waiting for an I<sup>2</sup>C communication.

**ADVANCED COMMUNICATIONS & SENSING**

I<sup>2</sup>C

The I<sup>2</sup>C interface gives access to the chip registers. It complies with the I<sup>2</sup>C protocol specifications, restricted to the slave side of the communication.

General features:

- Slave only operation
- Fast mode operation (up to 400 kHz)
- Combined read and write mode support
- General call reset support
- 7-bit device address customization
- Stretch I<sup>2</sup>C clock SCL only before sending ACK/NACK

The interface handles I<sup>2</sup>C communication at the transaction level: the processor is only aware of read and writes transactions. A read transaction is an external request to get the content of system memory location and a write transaction is an external request to write the content of a system memory location.

**I<sup>2</sup>C Communication Format**

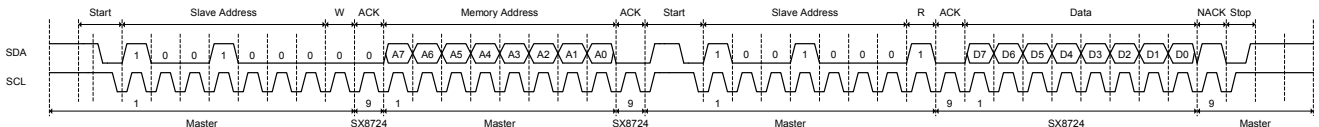

**Figure 5 - Timing Diagram for Reading from SX8724**

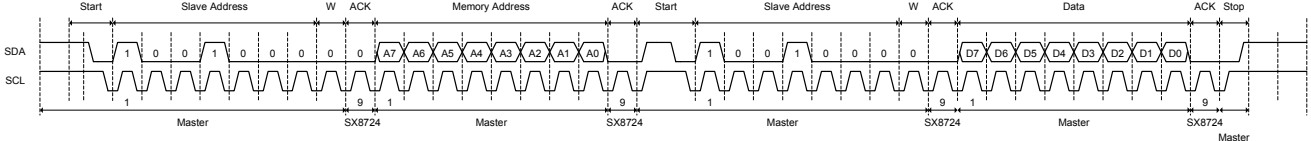

**Figure 6 - Timing Diagram for Writing to the SX8724**

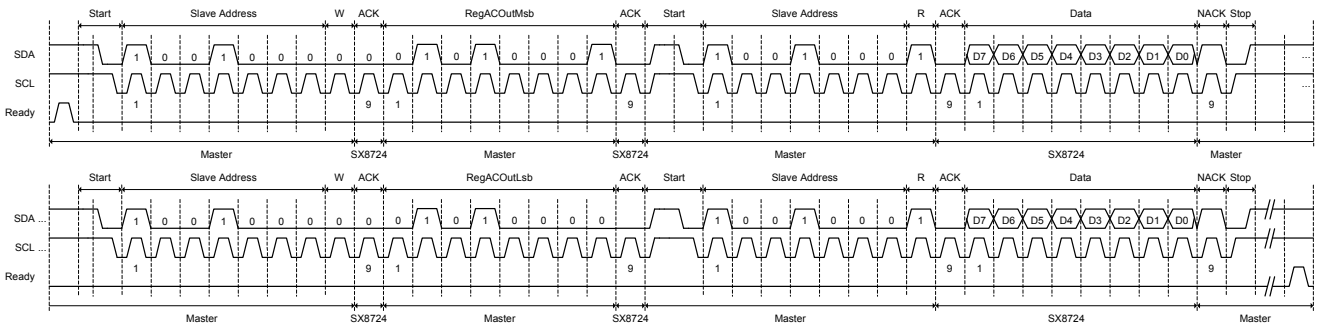

**Figure 7 - Timing Diagram for Reading an ADC Sample from SX8724**

**I<sup>2</sup>C Address**

The default I<sup>2</sup>C slave address is 1001000 in binary. This is the standard part I<sup>2</sup>C slave address. Other addresses between 1001001 and 1001111 are available by special request.

## ZoomingADC

### Features

The ZoomingADC is a complete and versatile low-power analog front-end interface typically intended for sensing applications.

In the following text the ZoomingADC will be referred as ZADC.

The key features of the ZADC are:

- Programmable 6 to 16-bit dynamic range over-sampled ADC
- Flexible gain programming between 0.5 and 1000
- Flexible and large range offset compensation
- 4-channel differential or 7-channel single-ended input
- 2-channel differential reference inputs
- Power saving modes

### Overview

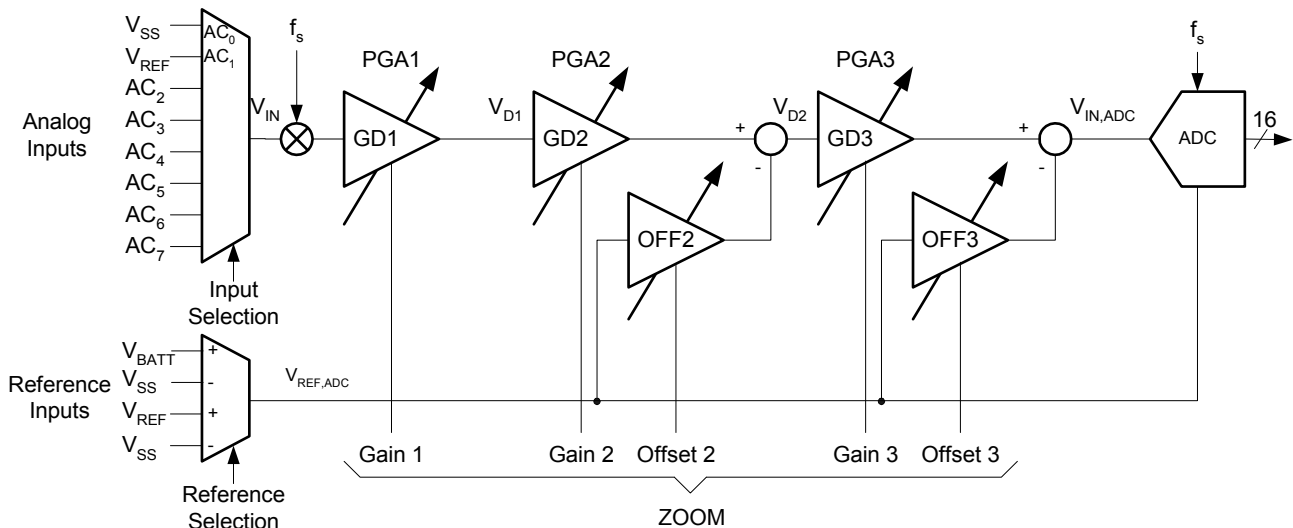

**Figure 8 - ZADC General Functional Block Diagram**

The total acquisition chain consists of an input multiplexer, 3 programmable gain amplifier stages and an over sampled A/D converter. The reference voltage can be selected on two different channels. Two offset compensation amplifiers allow for a wide offset compensation range. The programmable gain and offset allow the application to zoom in on a small portion of the reference voltage defined input range.

### ZADC Description

#### Acquisition Chain

Figure 8 shows the general block diagram of the acquisition chain (AC). A control block (not shown in Figure 8) manages all communications with the I2C peripheral. The clocking is derived from the internal 4 MHz Oscillator.

Analog inputs can be selected through an 8 input multiplexer, while reference input is selected between two differential channels. It should however be noted that only 7 acquisition channels (including the  $V_{REF}$ ) are available when configured as single ended since the input amplifier is always operating in differential mode with both positive and negative input selected through the multiplexer.

The core of the zooming section is made of three differential programmable amplifiers (PGA). After selection of an input and reference signals  $V_{IN}$  and  $V_{REF,ADC}$  combination, the input voltage is modulated and amplified through stages 1 to 3. Fine gain programming up to 1'000 V/V is possible. In addition, the last two stages provide programmable offset. Each amplifier can be bypassed if needed.

The output of the PGA stages is directly fed to the analog-to-digital converter (ADC), which converts the signal  $V_{IN,ADC}$  into digital.

Like most ADCs intended for instrumentation or sensing applications, the ZoomingADC is an over-sampled converter (See Note<sup>1</sup>). The ADC is a so-called incremental converter; with bipolar operation (the ADC accepts both positive and negative differential input voltages). In first approximation, the ADC output result relative to full-scale ( $FS$ ) delivers the quantity:

$$\frac{OUT_{ADC}}{F_S / 2} \cong \frac{V_{IN,ADC}}{V_{REF,ADC} / 2}$$

**Equation 1**

in two's complement (see Equation 4 and Equation 5 for details). The output code  $OUT_{ADC}$  is  $-FS/2$  to  $+FS/2$  for  $V_{IN,ADC} \cong -V_{REF,ADC}/2$  to  $+V_{REF,ADC}/2$  respectively. As will be shown,  $V_{IN,ADC}$  is related to input voltage  $V_{IN}$  by the relationship:

$$V_{IN,ADC} = GD_{TOT} \cdot V_{IN} - GDoff_{TOT} \cdot V_{REF,ADC} \quad (V)$$

**Equation 2**

where  $GD_{TOT}$  is the total PGA gain, and  $GDoff_{TOT}$  is the total PGA offset.

<sup>1</sup> Note: Over-sampled converters are operated with a sampling frequency  $f_S$  much higher than the input signal's Nyquist rate (typically  $f_S$  is 20-1'000 times the input signal bandwidth). The sampling frequency to throughput ratio is large (typically 10-500). These converters include digital decimation filtering. They are mainly used for high resolution, and/or low-to-medium speed applications.



**ADVANCED COMMUNICATIONS & SENSING**

**Registers**

The system has a bank of eight 8-bit registers: six registers are used to configure the acquisition chain (**RegAcCfg0** to **5**), and two registers are used to store the output code of the analog-to-digital conversion (**RegAcOutMsb** & **Lsb**).

Register Name	Bit Position								
	7	6	5	4	3	2	1	0	
RegACOutLsb	OUT[7:0]								
RegACOutMsb	OUT[15:8]								
RegACCfg0 Default values:	START 0	SET_NELC[1:0] 01	SET_OSR[2:0] 010			CONT 0	-		0
RegACCfg1 Default values:	IB_AMP_ADC[1:0] 11		IB_AMP_PGA[1:0] 11		ENABLE[3:0] 0000				
RegACCfg2 Default values:	FIN[1:0] 00		PGA2_GAIN[1:0] 00		PGA2_OFFSET[3:0] 0000				
RegACCfg3 Default values:	PGA1_G 0	PGA3_GAIN[6:0] 0001100							
RegACCfg4 Default values:	- 0	PGA3_OFFSET[6:0] 0000000							
RegACCfg5 Default values:	BUSY 0	DEF 0	AMUX[4:0] 00000				VMUX 0		

**Table 1 - Peripheral Registers to Configure the Acquisition Chain (AC) and to Store the Analog-to-Digital Conversion (ADC) Result**

With:

- OUT: (r) digital output code of the analog-to-digital converter. (MSB = OUT[15])
  - START: (w) setting this bit triggers a single conversion (after the current one is finished). This bit always reads back 0.
  - SET\_NELC: (rw) sets the number of elementary conversions to 2 SET\_NELC[1:0]. To compensate for offsets, the input signal is chopped between elementary conversions (1,2,4,8).
  - SET\_OSR: (rw) sets the over-sampling rate (OSR) of an elementary conversion to 2(3+SET\_OSR[2:0]). OSR = 8, 16, 32, ..., 512, 1024.
  - CONT: (rw) setting this bit starts a conversion. A new conversion will automatically begin as long as the bit remains at 1.
  - TEST: bit only used for test purposes. In normal mode, this bit is forced to 0 and cannot be overwritten.
  - IB\_AMP\_ADC: (rw) sets the bias current in the ADC to 0.25\*(1+ IB\_AMP\_ADC[1:0]) of the normal operation current (25, 50, 75 or 100% of nominal current). To be used for low-power, low-speed operation.
  - IB\_AMP\_PGA: (rw) sets the bias current in the PGAs to 0.25\*(1+IB\_AMP\_PGA[1:0]) of the normal operation current (25, 50, 75 or 100% of nominal current). To be used for low-power, low-speed operation.
  - ENABLE: (rw) enables the ADC modulator (bit 0) and the different stages of the PGAs (PGA<sub>i</sub> by bit i=1,2,3). PGA stages that are disabled are bypassed.
  - FIN: (rw) These bits set the over sampling frequency of the acquisition chain. Expressed as a fraction of the oscillator frequency, the sampling frequency is given as: 11 → 500 kHz, 10 → 250 kHz, 01 → 125 kHz, 00 → 62.5 kHz.
  - PGA1\_GAIN: (rw) sets the gain of the first stage: 0 → 1, 1 → 10.
  - PGA2\_GAIN: (rw) sets the gain of the second stage: 00 → 1, 01 → 2, 10 → 5, 11 → 10.
  - PGA3\_GAIN: (rw) sets the gain of the third stage to PGA3\_GAIN[6:0]:1/12.
  - PGA2\_OFFSET: (rw) sets the offset of the second stage between -1 and +1, with increments of 0.2. The MSB gives the sign (0 → positive, 1 → negative); amplitude is coded with the bits PGA2\_OFFSET[5:0].
  - PGA3\_OFFSET: (rw) sets the offset of the third stage between -5.25 and +5.25, with increments of 1/12. The MSB gives the sign (0 → positive, 1 → negative); amplitude is coded with the bits PGA3\_OFFSET[5:0].
  - BUSY: (r) set to 1 if a conversion is running.
  - DEF: (w) sets all values to their defaults (PGA disabled, max speed, nominal modulator bias current, 2 elementary conversions, over-sampling rate of 32) and starts a new conversion without waiting the end of the preceding one.
  - AMUX(4:0): (rw) AMUX(4) sets the mode (0 → differential inputs, 1 → single ended inputs with A<sub>0</sub> = common reference) AMUX(3) sets the sign (0 → straight, 1 → cross) AMUX(2:0) sets the channel.
  - VMUX: (rw) sets the differential reference channel (0 → V<sub>BATT</sub>, 1 → V<sub>REF</sub>).
- (r = read; w = write; rw = read & write)

## ZADC Detailed Functionality Description

### Continuous-Time vs. On-Request

The ADC can be operated in two distinct modes: "continuous-time" and "on-request" modes (selected using the bit CONT).

In "continuous-time" mode, the input signal is repeatedly converted into digital. After a conversion is finished, a new one is automatically initiated. The new value is then written in the result register, and the corresponding internal trigger pulse is generated. This operation is sketched in Figure 9. The conversion time in this case is defined as  $T_{CONV}$ .

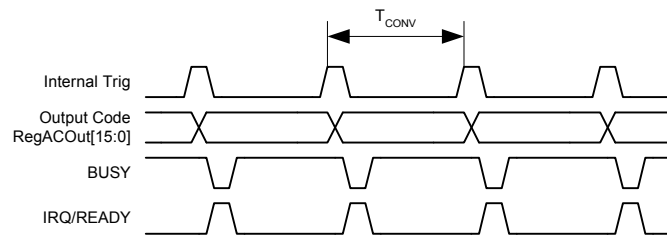

**Figure 9 - ADC "Continuous-Time" Operation**

In the "on-request" mode, the internal behavior of the converter is the same as in the "continuous-time" mode, but the conversion is initiated on user request (with the START bit). As shown in Figure 10, the conversion time is also  $T_{CONV}$ .

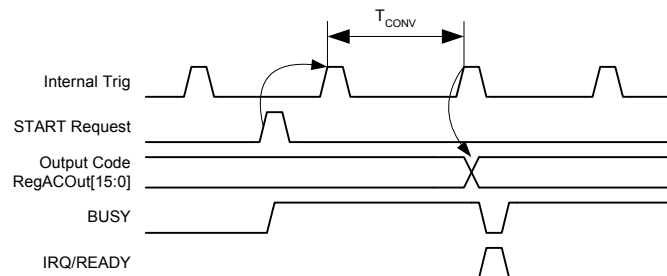

**Figure 10 - ADC "On-Request" Operation**

**Input Multiplexers**

The ZoomingADC has eight analog inputs AC<sub>0</sub> to AC<sub>7</sub> and four reference inputs AC\_R<sub>0</sub> to AC\_R<sub>3</sub>. Let us first define the differential input voltage V<sub>IN</sub> and reference voltage V<sub>REF,ADC</sub> respectively as:

$$V_{IN} = V_{INP} - V_{INN} \quad (V)$$

**Equation 3**

and:

$$V_{REF,ADC} = V_{REFP} - V_{REFN} \quad (V)$$

**Equation 4**

As shown in Table 2, the inputs can be configured in two ways: either as 4 differential channels (V<sub>IN1</sub> = AC<sub>1</sub> - AC<sub>0</sub>,..., V<sub>IN4</sub> = AC<sub>7</sub> - AC<sub>6</sub>), or AC<sub>0</sub> can be used as a common reference, providing 7 signal paths all referred to AC<sub>0</sub>. The control word for the analog input selection is AMUX[4:0]. Notice that the bit AMUX[3] controls the sign of the input voltage.

AMUX[4:0] (RegACCfg5[5:1])	V <sub>INP</sub>	V <sub>INN</sub>	AMUX[4:0] (RegACCfg5[5:1])	V <sub>INP</sub>	V <sub>INN</sub>
00x00	AC <sub>1</sub> (V <sub>REF</sub> )	AC <sub>0</sub> (V <sub>SS</sub> )	01x00	AC <sub>0</sub> (V <sub>SS</sub> )	AC <sub>1</sub> (V <sub>REF</sub> )
00x01	AC <sub>3</sub>	AC <sub>2</sub>	01x01	AC <sub>2</sub>	AC <sub>3</sub>
00x10	AC <sub>5</sub>	AC <sub>4</sub>	01x10	AC <sub>4</sub>	AC <sub>5</sub>
00x11	AC <sub>7</sub>	AC <sub>6</sub>	01x11	AC <sub>6</sub>	AC <sub>7</sub>
10000	AC <sub>0</sub> (V <sub>SS</sub> )	AC <sub>0</sub> (V <sub>SS</sub> )	11000	AC <sub>0</sub> (V <sub>SS</sub> )	AC <sub>0</sub> (V <sub>SS</sub> )
10001	AC <sub>1</sub> (V <sub>REF</sub> )		11001		AC <sub>1</sub> (V <sub>REF</sub> )
10010	AC <sub>2</sub>		11010		AC <sub>2</sub>
10011	AC <sub>3</sub>		11011		AC <sub>3</sub>
10100	AC <sub>4</sub>		11100		AC <sub>4</sub>
10101	AC <sub>5</sub>		11101		AC <sub>5</sub>
10110	AC <sub>6</sub>		11110		AC <sub>6</sub>
10111	AC <sub>7</sub>		11111		AC <sub>7</sub>

**Table 2 - Analog Input Selection**

Similarly, the reference voltage is chosen among two differential channels (V<sub>REF,ADC</sub> = AC\_R<sub>1</sub> - AC\_R<sub>0</sub> or V<sub>REF,ADC</sub> = AC\_R<sub>3</sub> - AC\_R<sub>2</sub>) as shown in Table 3. The selection bit is VMUX. The reference inputs V<sub>REFP</sub> and V<sub>REFN</sub> (common-mode) can be up to the power supply range.

VMUX (RegACCfg5[0])	V <sub>REFP</sub>	V <sub>REFN</sub>
0	AC_R <sub>1</sub> (V <sub>BATT</sub> )	AC_R <sub>0</sub> (V <sub>SS</sub> )
1	AC_R <sub>3</sub> (V <sub>REF</sub> )	AC_R <sub>2</sub> (V <sub>SS</sub> )

**Table 3 - Analog Reference Input Selection**

**Programmable Gain Amplifiers**

As seen in Figure 8, the zooming function is implemented with three programmable gain amplifiers (PGA). These are:

- PGA1: coarse gain tuning
- PGA2: medium gain and offset tuning
- PGA3: fine gain and offset tuning. Should be set ON for high linearity data acquisition

All gain and offset settings are realized with ratios of capacitors. The user has control over each PGA activation and gain, as well as the offset of stages 2 and 3. These functions are examined hereafter.

<b>ENABLE[3:0] (RegACCfg1[3:0])</b>	<b>Block</b>
xxx0	ADC disabled
xxx1	ADC enabled
xx0x	PGA1 disabled
xx1x	PGA1 enabled
x0xx	PGA2 disabled
x1xx	PGA2 enabled
0xxx	PGA3 disabled
1xxx	PGA3 enabled

**Table 4 - ADC & PGA Enabling**

<b>PGA1_GAIN (RegACCfg3[7])</b>	<b>PGA1 Gain GD<sub>1</sub> (V/V)</b>
0	1
1	10

**Table 5 - PGA1 Gain Settings**

<b>PGA2_GAIN[1:0] (RegACCfg2[5:4])</b>	<b>PGA2 Gain GD<sub>2</sub> (V/V)</b>
00	1
01	2
10	5
11	10

**Table 6 - PGA2 Gain Settings**

<b>PGA2_OFFSET[3:0] (RegACCfg2[3:0])</b>	<b>PGA2 Offset GDoff<sub>2</sub> (V/V)</b>
0000	0
0001	+0.2
0010	+0.4
0011	+0.6
0100	+0.8
0101	+1
1001	-0.2
1010	-0.4
1011	-0.6
1100	-0.8
1101	-1

**Table 7 - PGA2 Offset Settings**

<b>PGA3_GAIN[6:0] (RegACCfg3[6:0])</b>	<b>PGA3 Gain GD<sub>3</sub> (V/V)</b>
0000000	0
0000001	1/12(=0.083)
...	...
0000110	6/12
...	...
0001100	12/12
0010000	16/12
...	...
0100000	32/12
...	...
1000000	64/12
...	...
1111111	127/12(=10.58)

**Table 8 - PGA3 Gain Settings**

<b>PGA3_OFFSET[6:0] (RegACCfg4[6:0])</b>	<b>PGA3 Offset GDoff<sub>3</sub> (V/V)</b>
0000000	0
0000001	+1/12(=+0.083)
0000010	+2/12
...	...
0010000	+16/12
...	...
0100000	+32/12
...	...
0111111	+63/12(=+5.25)
1000000	0
1000001	-1/12(=-0.083)
1000010	-2/12
...	...
1010000	-16/12
...	...
1100000	-32/12
...	...
1111111	-63/12(=-5.25)

**Table 9 - PGA3 Offset Settings**

### PGA & ADC Enabling

Depending on the application objectives, the user may enable or bypass each PGA stage. This is done according to the word ENABLE and the coding given in Table 4. To reduce power dissipation, the ADC can also be inactivated while idle.

#### PGA1

The first stage can have a buffer function (unity gain) or provide a gain of 10 (see Table 5). The voltage  $V_{D1}$  at the output of PGA1 is:

$$V_{D1} = GD_1 \cdot V_{IN} \quad (V)$$

**Equation 5**

where  $GD_1$  is the gain of PGA1 (in V/V) controlled with the bit PGA1\_GAIN.

#### PGA2

The second PGA has a finer gain and offset tuning capability, as shown in Table 6 and Table 7. The voltage  $V_{D2}$  at the output of PGA2 is given by:

$$V_{D2} = GD_2 \cdot V_{D1} - GDoff_2 \cdot V_{REF,ADC} \quad (V)$$

**Equation 6**

where  $GD_2$  and  $GDoff_2$  are respectively the gain and offset of PGA2 (in V/V). These are controlled with the words PGA2\_GAIN[1:0] and PGA2\_OFFSET[3:0].

#### PGA3

The finest gain and offset tuning is performed with the third and last PGA stage, according to the coding of Table 8 and Table 9. The output of PGA3 is also the input of the ADC. Thus, similarly to PGA2, we find that the voltage entering the ADC is given by:

$$V_{IN,ADC} = GD_3 \cdot V_{D2} - GDoff_3 \cdot V_{REF,ADC} \quad (V)$$

**Equation 7**

where  $GD_3$  and  $GDoff_3$  are respectively the gain and offset of PGA3 (in V/V). The control words are PGA3\_GAIN[6:0] and PGA3\_OFFSET[6:0]. To remain within the signal compliance of the PGA stages, the condition:

$$V_{D1} \cdot V_{D2} < V_{DD} \quad (V)$$

**Equation 8**

must be verified.

Finally, combining equations 5 to 7 for the three PGA stages, the input voltage  $V_{IN,ADC}$  of the ADC is related to  $V_{IN}$  by:

$$V_{IN,ADC} = GD_{TOT} \cdot V_{IN} - GDoff_{TOT} \cdot V_{REF,ADC} \quad (V)$$

**Equation 9**

where the total PGA gain is defined as:

$$GD_{TOT} = GD_3 \cdot GD_2 \cdot GD_1 \quad (V/V)$$

**Equation 10**

and the total PGA offset is:

$$GDoff_{TOT} = GDoff_3 + GD_3 \cdot GDoff_2 \quad (V/V)$$

**Equation 11**

### ADC Characteristics

The main performance characteristics of the ADC (resolution, conversion time, etc.) are determined by three programmable parameters. The setting of these parameters and the resulting performances are described later.

- Over-sampling frequency  $f_s$
- Over-Sampling Ratio OSR
- Number of Elementary Conversions NELCONV

### Conversion Sequence

A conversion is started each time the bit START or the bit DEF is set. As depicted in Figure 11, a complete analog-to-digital conversion sequence is made of a set of  $N_{ELCONV}$  elementary incremental conversions and a final quantization step. Each elementary conversion is made of  $(OSR+1)$  over-sampling periods  $T_s=1/f_s$ , i.e.:

$$T_{ELCONV} = \frac{(OSR + 1)}{f_s} \quad (s)$$

**Equation 12**

The result is the mean of the elementary conversion results. An important feature is that the elementary conversions are alternatively performed with the offset of the internal amplifiers contributing in one direction and the other to the output code. Thus, converter internal offset is eliminated if at least two elementary sequences are performed (i.e. if  $N_{ELCONV} \geq 2$ ). A few additional clock cycles are also required to initiate and end the conversion properly.

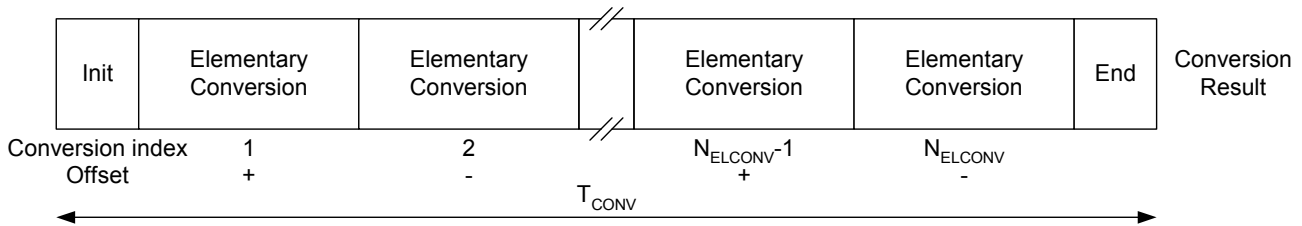

**Figure 11 - Analog-to-Digital Conversion Sequence**

#### Note:

The internal bandgap reference state may be forced High or Low, or may be set to toggle during conversion at either the same rate or half the rate of the Elementary Conversion. This may be useful to help eliminate bandgap related internal offset voltage and  $1/f_s$  noise.

### Over-Sampling Frequency

The word FIN[1:0] (see Table 10) is used to select the over-sampling frequency  $f_s$ . The over-sampling frequency is derived from the 4MHz oscillator clock.

FIN[1:0] (RegACCfg2[7:6])	Over-Sampling Frequency $f_s$ (Hz)
00	62.5 kHz
01	125 kHz
10	250 kHz
11	500 kHz

**Table 10 - Over-Sampling Frequency Settings**

### Over-Sampling Ratio

The over-sampling ratio (*OSR*) defines the number of integration cycles per elementary conversion. Its value is set with the word SET\_OSR[2:0] in power of 2 steps (see Table 11) given by:

$$OSR = 2^{3+SET\_OSR[2:0]}$$

**Equation 13**

SET_OSR[2:0] (RegACCfg0[4:2])	Over-Sampling Ratio OSR (-)
000	8
001	16
010	32
011	64
100	128
101	256
110	512
111	1024

**Table 11 - Over-Sampling Ratio Settings**

### Elementary Conversions

As mentioned previously, the whole conversion sequence is made of a set of  $N_{ELCONV}$  elementary incremental conversions. This number is set with the word SET\_NELC[1:0] in power of 2 steps (see Table 12) given by:

$$N_{ELCONV} = 2^{SET\_NELC[1:0]}$$

**Equation 14**

SET_NELC[1:0] (RegACCfg0[6:5])	# of Elementary Conversions $N_{ELCONV}$ (-)
00	1
01	2
10	4
11	8

**Table 12 - Number of Elementary Conversion Settings**

As already mentioned,  $N_{ELCONV}$  must be equal or greater than 2 to reduce internal amplifier offsets.

**Resolution**

The theoretical resolution of the ADC, without considering thermal noise, is given by:

$$n = 2 \cdot \log_2(OSR) + \log_2(N_{ELCONV}) \quad (\text{Bits})$$

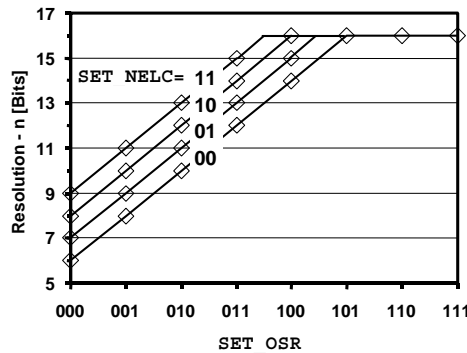
**Equation 15**

**Figure 12 - Resolution vs. SET\_OSR[2:0] and SET\_NELC[1:0]**

Using look-up Table 13 or the graph plotted in Figure 12, resolution can be set between 6 and 16 bits. Notice that, because of 16-bit register use for the ADC output, **practically the resolution is limited to 16 bits**, i.e.  $n \leq 16$ . Even though the resolution is truncated to 16 bit by the output register size, it may make sense to set OSR and  $N_{ELCONV}$  to higher values in order to reduce the influence of the thermal noise in the PGA and of external noises (see section “PGA Gain & Offset, Linearity and Noise” in page 37).

SET_OSR [2:0]	SET_NELC[1:0]			
	00	01	10	11
000	6	7	8	9
001	8	9	10	11
010	10	11	12	13
011	12	13	14	15
100	14	15	16	16
101	16	16	16	16
110	16	16	16	16
111	16	16	16	16

**Note:** shaded area: resolution truncated to 16 bits due to output register size RegACOut[15:0]

**Table 13 - Resolution vs. SET\_OSR[2:0] and SET\_NELC[1:0] Settings**



**Conversion Time and Throughput**

As explained in Figure 12, conversion time is given by:

$$T_{CONV} = \frac{N_{ELCONV} \cdot (OSR + 1) + 1}{f_s} \quad (s) \quad (16)$$

**Equation 16**

and throughput is then simply  $1/T_{CONV}$ . For example, consider an over-sampling ratio of 256, 2 elementary conversions, and a over-sampling frequency of 500kHz (SET\_OSR = "101", SET\_NELC = "01", FIN = "00"). In this case, using Table 14, the conversion time is 515 over-sampling periods, or 1.03ms. This corresponds to a throughput of 971Hz in continuous-time mode. The plot of Figure 7 illustrates the classic trade-off between resolution and conversion time.

SET_OSR [2:0]	SET_NELC[1:0]			
	00	01	10	11
000	10	19	37	73
001	18	35	69	137
010	34	67	133	265
011	66	131	261	521
100	130	259	517	1033
101	258	515	1029	2057
110	514	1027	2053	4105
111	1026	2051	4101	8201

**Table 14 - Normalized Conversion Time ( $T_{CONV} \cdot f_s$ ) vs. SET\_OSR[2:0] and SET\_NELC[1:0] (Normalized to Over-Sampling Period  $1/f_s$ )**
**Note**

Some high sample rate configurations can not be used due to I2C speed limitation.

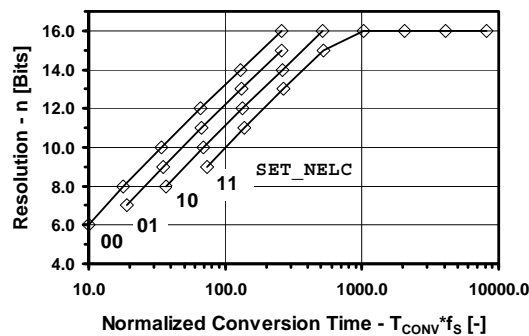
**Figure 13 - Resolution vs. Normalized Conversion Time for Different SET\_NELC[1:0]**

**Output Code Format**

The ADC output code is a 16-bit word in two's complement format (see Table 15). For input voltages outside the range, the output code is saturated to the closest full-scale value (i.e. 0x7FFF or 0x8000). For resolutions smaller than 16 bits, the non-significant bits are forced to the values shown in Table 16. The output code, expressed in LSBs, corresponds to:

$$OUT_{ADC} = 2^{16} \cdot \frac{V_{IN,ADC}}{V_{REF,ADC}} \cdot \frac{OSR+1}{OSR} \quad (\text{LSB})$$

**Equation 17**

Recalling equation 9, this can be rewritten as:

$$OUT_{ADC} = 2^{16} \cdot \frac{V_{IN}}{V_{REF,ADC}} \cdot \left( GD_{TOT} - GD_{off_{TOT}} \cdot \frac{V_{REF,ADC}}{V_{IN}} \right) \cdot \frac{OSR+1}{OSR} \quad (\text{LSB})$$

**Equation 18**

where, from Equation 10 and Equation 11, the total PGA gain and offset are respectively:

$$GD_{TOT} = GD_3 \cdot GD_2 \cdot GD_1 \quad (V/V)$$

and:

$$GD_{off_{TOT}} = GD_{off_3} + GD_3 \cdot GD_{off_2} \quad (V/V)$$

ADC Input Voltage $V_{IN,ADC}$	% of Full Scale (FS)	Output in LSBs	Output Code in Hex
+2.46146V	+0.5-FS	+215-1=+32'767	7FFF
+2.46138V	...	+215-2=+32'766	7FFE
...	...	...	...
+75μV	...	+1	0001
0V	0	0	0000
-75μV	...	-1	8FFF
...	...	...	...
-2.46146V	...	-215-1=-32'767	8001
-2.46154V	-0.5-FS	-215=-32'768	8000

**Table 15 - Basic ADC Relationships (example for:  $V_{REF,ADC} = 5V$ ,  $OSR = 64$ ,  $n = 16$  bits)**

SET_OSR[2:0]	SET_NELC = 00	SET_NELC = 01	SET_NELC = 10	SET_NELC = 11
000	1000000000	1000000000	1000000000	1000000000
001	1000000000	1000000000	1000000000	1000000000
010	1000000000	1000000000	1000000000	1000000000
011	1000000000	1000000000	1000000000	1000000000
100	1000000000	1000000000	1000000000	1000000000
101	-	-	-	-
110	-	-	-	-
111	-	-	-	-

**Table 16 - Last Forced LSBs in Conversion Output Registers for Resolution Settings Smaller than 16 bits ( $n < 16$ ) (RegACOutMsb[7:0] & RegACOutLsb[7:0])**

The equivalent LSB size at the input of the PGA chain is:

$$LSB = \frac{1}{2^n} \cdot \frac{V_{REF,ADC}}{GD_{TOT}} \cdot \frac{OSR}{OSR + 1} \quad (V)$$

**Equation 19**

Notice that the input voltage  $V_{IN,ADC}$  of the ADC must satisfy the condition:

$$|V_{IN,ADC}| \leq \frac{1}{2} \cdot (V_{REFP} - V_{REFN}) \cdot \frac{OSR}{OSR + 1} \quad (V)$$

**Equation 20**

to remain within the ADC input range.

### Power Saving Modes

During low-speed operation, the bias current in the PGAs and ADC can be programmed to save power using the control words  $IB\_AMP\_PGA[1:0]$  and  $IB\_AMP\_ADC[1:0]$  (see Table 17). If the system is idle, the PGAs and ADC can even be disabled, thus, reducing power consumption to its minimum. This can considerably improve battery life.

<b>IB_AMP_ADC[1:0] (RegACCfg1[7:6])</b>	<b>IB_AMP_PGA[1:0] (RegACCfg1[5:4])</b>	<b>ADC Bias Current</b>	<b>PGA Bias Current</b>	<b>Max. f<sub>s</sub> [kHz]</b>
00	x	1/4·IADC	x	125
01		1/2· IADC		250
11		IADC		500
x	00	x	1/4·IPGA	125
	01		1/2· IPGA	250
	11		IPGA	500

**Table 17 - ADC & PGA Power Saving Modes and Maximum Sampling Frequency**

### Registers Map

Address	Register	Bits	Description
<b>RC Register</b>			
0x30	RegRCen	1	RC oscillator control
<b>GPIO Registers</b>			
0x40	RegOut	8	D0 to D3 pads data output and direction control
0x41	RegIn	4	D0 to D3 pads input data
<b>ADC Registers</b>			
0x50	RegACOutLsb	8	LSB of the ADC result
0x51	RegACOutMsb	8	MSB of the ADC result
0x52	RegACCfg0	7	ADC conversion control
0x53	RegACCfg1	8	ADC conversion control
0x54	RegACCfg2	8	ADC conversion control
0x55	RegACCfg3	8	ADC conversion control
0x56	RegACCfg4	7	ADC conversion control
0x57	RegACCfg5	8	ADC conversion control
<b>Mode Register</b>			
0x70	RegMode	6	Chip operating mode register

### Registers Descriptions

The register descriptions are presented here in ascending order of Register Address. Some registers carry several individual data fields of various sizes; from single-bit values (e.g. flags), upwards. Some data fields are spread across multiple registers. Unused bits are 'don't care' and writing either 0 or 1 will not affect any function of the device. After power on reset the registers will have the values indicated in the tables "Reset" column.

#### RC Register

Bit	Name	Mode	Reset	Description
7:1	-	r	000000	unused
0	RC_EN	rw	1	Enables RC oscillator. Set 0 for low power mode.

**Table 18 - RegRCen (0x30)**

**GPIO Registers**

Bit	Name	Mode	Reset	Description
7	D3_DIR	rw	1	D3 pad direction: 1 = Output 0 = Input
6	D2_DIR	rw	1	D2 pad direction: 1 = Output 0 = Input
5	D1_DIR	rw	1	D1 pad direction: 1 = Output 0 = Input
4	D0_DIR	rw	1	D0 pad direction: 1 = Output 0 = Input
3	D3_OUT	rw	0	D3 pad output value. Only valid when D3_DIR = 1
2	D2_OUT	rw	0	D2 pad output value. Only valid when D2_DIR = 1
1	D1_OUT	rw	0	D1 pad output value. Only valid when D1_DIR = 1 and VREF_D1_IN = 0
0	D0_OUT	rw	0	D0 pad output value. Only valid when D0_DIR = 1 and VREF_D0_OUT = 0

**Table - 19 RegOut (0x40)**

Bit	Name	Mode	Reset	Description
7:4	-	r	0000	Unused
3	D3_IN	r	-	D3 pad value
2	D2_IN	r	-	D2 pad value
1	D1_IN	r	-	D1 pad value
0	D0_IN	r	-	D0 pad value

**Table - 20 RegIn (0x41)**

**ZADC Registers**

Bit	Name	Mode	Reset	Description
7:0	OUT[7:0]	r	00000000	LSB of the ADC result

**Table 21 - RegACOutLsb (0x50)**

Bit	Name	Mode	Reset	Description
7:0	OUT[15:8]	r	00000000	MSB of the ADC result

**Table 22 - RegACOutMsb (0x51)**

Bit	Name	Mode	Reset	Description
7	START	rw	0	Starts an ADC conversion
6:5	SET_NELC[1:0]	rw	01	Sets the number of elementary conversions
4:2	SET_OSR[2:0]	rw	010	Sets the ADC over-sampling rate
1	CONT	rw	0	Sets continuous ADC conversion mode
0	-	r	0	unused

**Table 23 - RegACCfg0 (0x52)**

Bit	Name	Mode	Reset	Description
7:6	IB_AMP_ADC[1:0]	rw	11	Bias current selection for the ADC
5:4	IB_AMP_PGA[1:0]	rw	11	Bias current selection for the PGA
3:0	ENABLE[3:0]	rw	0000	ADC and PGA stage enables

**Table 24 - RegACCfg1 (0x53)**

Bit	Name	Mode	Reset	Description
7:6	FIN[1:0]	rw	00	ADC Sampling Frequency selection
5:4	PGA2_GAIN[1:0]	rw	00	PGA2 gain selection
3:0	PGA2_OFFSET[3:0]	rw	0000	PGA2 offset selection

**Table 25 - RegACCfg2 (0x54)**

Bit	Name	Mode	Reset	Description
7	PGA1_GAIN	rw	0	PGA1 gain selection
6:0	PGA3_GAIN[6:0]	rw	0001100	PGA3 gain selection

**Table 26 - RegACCfg3 (0x55)**

Bit	Name	Mode	Reset	Description
7	-			
6:0	PGA3_OFFSET[6:0]	rw	0000000	PGA3 offset selection

**Table 27 - RegACCfg4 (0x56)**

Bit	Name	Mode	Reset	Description
7	BUSY	r	0	ADC activity flag
6	DEF	rw	0	Selects ADC & PGA default configuration
5:1	AMUX[4:0]	rw	00000	Input channel configuration selector
0	VMUX	rw	0	Reference source selector ( $V_{BATT} = 0$ or $V_{REF} = 1$ )

**Table 28 - RegACCfg5 (0x57)**

**Mode Register**

Bit	Name	Mode	Reset	Function
7	MULT_READY	r	1	1: Indicates that the charge pump has settled and the output voltage is sufficient for conversion
6	MULT_ACTIVE	r	0	1: Indicates that the charge pump is running (either because VBATT<3V or it has been forced on)
5:4	CHOP	rw	00	VREF chopping control 11: Chop at Nelconv/2 rate 10: Chop at Nelconv rate 01: Chop state = 1 00: Chop state = 0 (Note 1)
3	MULT_FORCE_ON	rw	0	Force charge pump On (takes priority) (Note 2)
2	MULT_FORCE_OFF	rw	1	Force charge pump Off (Note 2)
1	VREF_D0_OUT	rw	0	Enable VREF output on D0 pin
0	VREF_D1_IN	rw	0	Enable VREF input on D1 pin

Note1: The chop control is to allow chopping of the internal bandgap reference. This may be useful to help eliminate bandgap related internal offset voltage and 1/f noise. The bandgap chop state may be forced High or Low, or may be set to toggle during conversion at either the same rate or half the rate of the Elementary Conversion. (See Conversion Sequence in the ZoomingADC description)

Note2: The internal charge pump may be forced On or Off to avoid conversion interruptions due to the pump switching off and on when the  $V_{BATT}$  supply is near 3V. If the pump is on automatic, then it will activate when  $V_{BATT}$  drops below 3V to ensure sufficient supply to the ADC. If the ADC is not being run at full rate or full accuracy then it may operate sufficiently well when  $V_{BATT}$  is less than 3V.

**Table 29 - RegMode (0x70)**

**Optional Operating Modes: External Voltage Reference Option**

D0 and D1 are multi-functional pins with the following functions in different operating modes (see **RegMode** register for control settings):

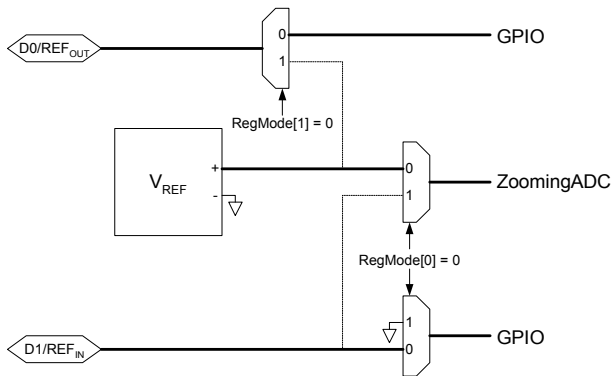

**Figure 14 - D0 and D1 are Digital Inputs / Outputs**

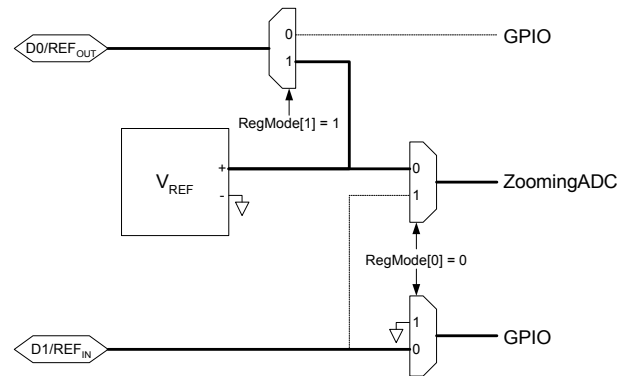

**Figure 16 - D0 is Reference Voltage Output and D1 is Digital Input / Output**

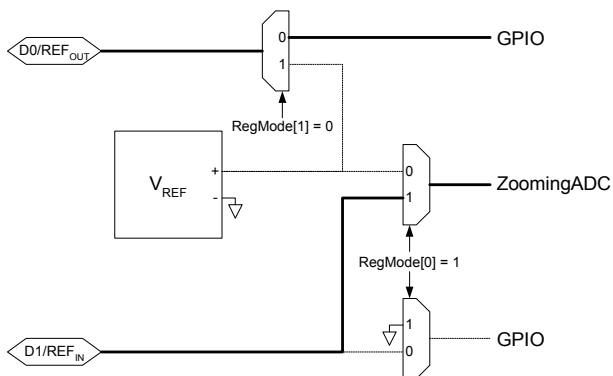

**Figure 15 - D0 is Digital Input / Output and D1 Reference Voltage Input**

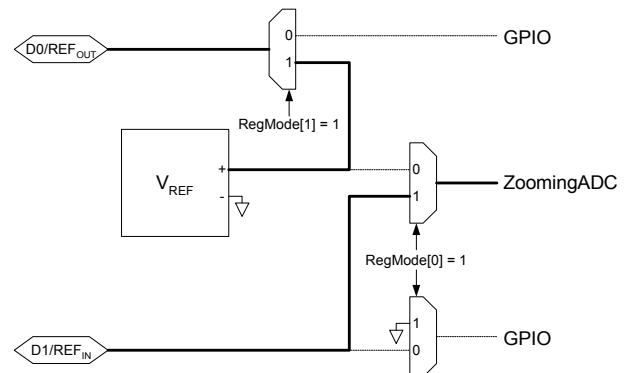

**Figure 17 - D0 is Reference Voltage Output and D1 is Reference Voltage Input**

This allows external monitoring of the internal bandgap reference or the ability to use an external reference input for the ADC, or the option to filter the internal  $V_{REF}$  output before feeding back as  $V_{REF,ADC}$  input.

The internally generated  $V_{REF}$  is a trimmed bandgap reference with a nominal value of 1.22V.

**When using an external  $V_{REF,ADC}$  input, it may have any value between 0V and  $V_{BATT}$ . Simply substitute the external value for 1.22 V in the ADC conversion calculations.**



## Application Hints

### Recommended Operation Mode and Registers Settings

#### Operation Mode

Parameter	Value	Units
<b>Analog multiplexers</b>		
VMUX	VBATT	
AMUX	VINP = AC3 & VINN = AC2	
<b>PGA</b>		
PGA1 Gain	OFF	V/V
PGA2 Gain	OFF	V/V
PGA3 Gain	1	V/V
Total Offset	0	V/V
PGA2 Offset	OFF	V/V
PGA3 Offset	0	V/V
ADC Bias	50	%
PGA Bias	50	%
<b>ADC</b>		
fs	250	kHz
Resolution	16	Bits
OSR	512	OverSamples / ElementaryConversion
NELCONV	2	ElementaryConversion / Conversion
Continuous mode	ON	-

**Table 30 - Recommended Operation Mode Values**

#### Registers Settings

Register Name	Bit Position								Hexadecimal Value
	7	6	5	4	3	2	1	0	
RegACOutLsb	OUT[7:0]								XXXXXXXX
RegACOutMsb	OUT[15:8]								XXXXXXXX
RegACCfg0	START 0	SET_NELC[1:0] 01	SET_OSR[2:0] 110			CONT 1	- 0		0x3A
RegACCfg1	IB_AMP_ADC[1:0] 01		IB_AMP_PGA[1:0] 01		ENABLE[3:0] 1001				0x59
RegACCfg2	FIN[1:0] 10		PGA2_GAIN[1:0]		PGA2_OFFSET[3:0] 0000				0x80
RegACCfg3	PGA1_G 0	PGA3_GAIN[6:0] 0001100							0x0C
RegACCfg4	- 0	PGA3_OFFSET[6:0] 0000000							0x00
RegACCfg5	BUSY 0	DEF 0	AMUX[4:0] 00001				VMUX 0		0x02

**Table 31 - Registers Settings**

Schematic

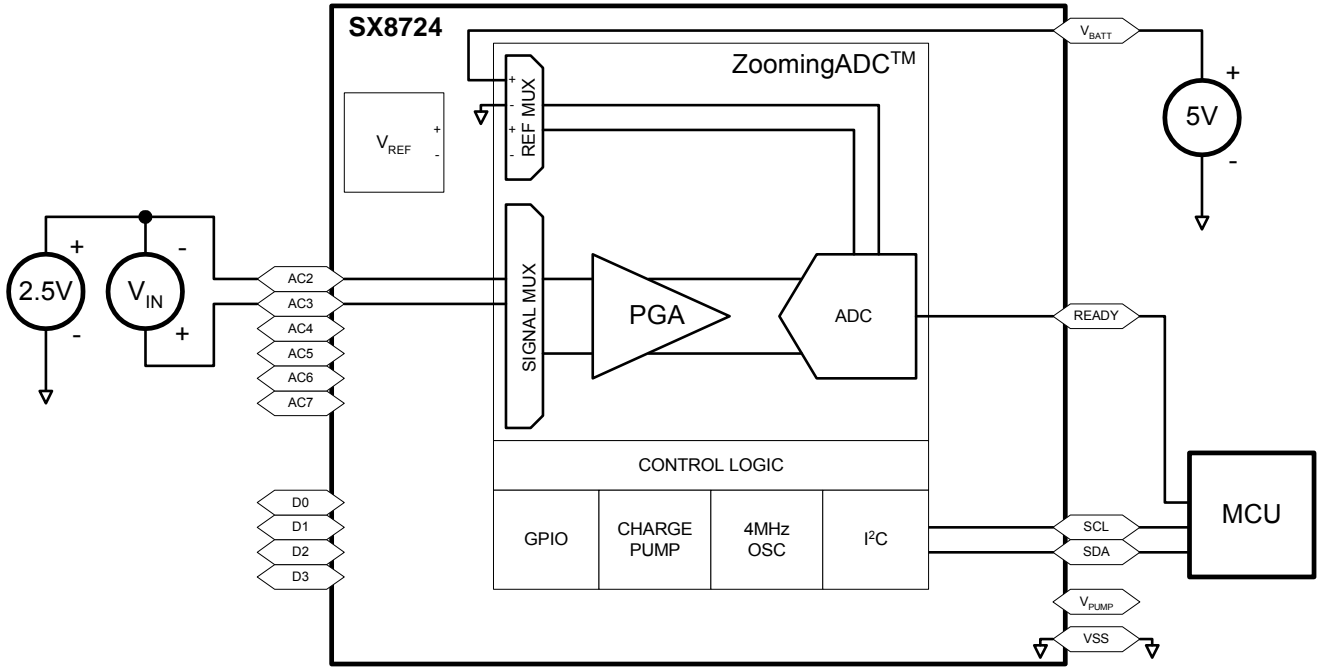

Figure 18 - Recommended Operation Mode Schematic

### Input Impedance

The PGAs of the ZoomingADC are a switched capacitor based blocks (see Switched Capacitor Principle chapter). This means that it does not use resistors to fix gains, but capacitors and switches. This has important implications on the nature of the input impedance of the block.

Using switched capacitors is the reason why, while a conversion is done, the input impedance on the selected channel of the PGAs is inversely proportional to the sampling frequency  $f_s$  and to stage gain as given in Equation 21.

$$Z_{in} \geq \frac{768 \cdot 10^9 \Omega \text{Hz}}{f_s \cdot \text{gain}} \quad (\Omega)$$

**Equation 21**

The input impedance observed is the input impedance of the first PGA stage that is enabled or the input impedance of the ADC if all three stages are disabled.

PGA1 (with a gain of 10), PGA2 (with a gain of 10) and PGA3 (with a gain of 10) each have a minimum input impedance of 150 k $\Omega$  at  $f_s = 500$  kHz (see ZoomingADC Specifications). Larger input impedance can be obtained by reducing the gain and/or by reducing the sampling frequency. Therefore, with a gain of 1 and a sampling frequency of 125 kHz,  $Z_{in} > 6.1\text{M}\Omega$ .

The input impedance on channels that are not selected is very high (>100M $\Omega$ ).

**Switched Capacitor Principle**

Basically, a switched capacitor is a way to emulate a resistor by using a capacitor. The capacitors are much easier to realize on CMOS technologies and they show a very good matching precision.

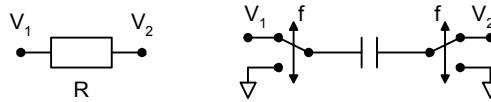

**Figure 19 - The Switched Capacitor Principle**

A resistor is characterized by the current that flows through it (positive current leaves node  $V_1$ ):

$$I = \frac{V_1 - V_2}{R} \quad (A)$$

**Equation 22**

One can verify that the mean current leaving node  $V_1$  with a capacitor switched at frequency  $f$  is:

$$\langle I \rangle = (V_1 - V_2) \cdot f \cdot C \quad (A)$$

**Equation 23**

Therefore as a mean value, the switched capacitor  $\frac{1}{f \cdot C}$  is equivalent to a resistor.

It is important to consider that this is only a mean value. If the current is not integrated (low impedance source), the impedance is infinite during the whole time but the transition.

What does it mean for the ZoomingADC?

If the  $f_s$  clock is reduced, the mean impedance is increased. By dividing the  $f_s$  clock by a factor 10, the impedance is increased by a factor 10.

One can reduce the capacitor that is switched by using an amplifier set to its minimal gain. In particular if PGA1 is used with gain 1, its mean impedance is 10x bigger than when it is used with gain 10.

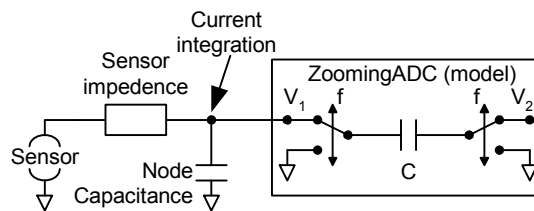

**Figure 20 - The Switched Capacitor Principle**

One can increase the effective impedance by increasing the electrical bandwidth of the sensor node so that the switching current is absorbed through the sensor before the switching period is over. Measuring the sensor node will show short voltage spikes at the frequency  $f_s$ , but these will not influence the measurement. Whereas if the bandwidth of the node is lower, no spikes will arise, but a small offset can be generated by the integration of the charges generated by the switched capacitors, this corresponds to the mean impedance effect.

**Note:**

One can increase the mean input impedance of the ZoomingADC by lowering the acquisition clock  $f_s$ .

One can increase the mean input impedance of the ZoomingADC by decreasing the gain of the first enabled amplifier.

One can increase the effective input impedance of the ZoomingADC by having a source with a high electrical bandwidth (sensor electrical bandwidth much higher than  $f_s$ ).

### PGA Settling or Input Channel Modifications

PGAs are reset after each writing operation to registers **RegAcCfg1-5**. Similarly, input channels are switched after modifications of AMUX[4:0] or VMUX. To ensure precise conversion, the ADC must be started after a PGA or inputs common-mode stabilization delay. This is done by writing bit START several cycles after PGA settings modification or channel switching. Delay between PGA start or input channel switching and ADC start should be equivalent to OSR (between 8 and 1024) number of cycles. This delay does not apply to conversions made without the PGAs.

If the ADC is not settled within the specified period, there is most probably an input impedance problem (see previous section).

### PGA Gain & Offset, Linearity and Noise

Hereafter are a few design guidelines that should be taken into account when using the ZoomingADC™:

1. Keep in mind that increasing the overall PGA gain, or "zooming" coefficient, improves linearity but degrades noise performance.
2. Use the minimum number of PGA stages necessary to produce the desired gain ("zooming") and offset. Bypass unnecessary PGAs.
3. Put most gain on PGA3 and use PGA2 and PGA1 only if necessary.
4. PGA3 should be always ON for best linearity.
5. For low-noise applications where power consumption is not a primary concern, maintain the largest bias currents in the PGAs and in the ADC; i.e. set IB\_AMP\_PGA[1:0] = IB\_AMP\_ADC[1:0] = '11'.
6. For lowest output offset error at the output of the ADC, bypass PGA2 and PGA3. Indeed, PGA2 and PGA3 typically introduce an offset of about 5 to 10 LSB (16 bit) at their output. Note, however, that the ADC output offset is easily calibrated out by software.

### Frequency Response

The incremental ADC is an over-sampled converter with two main blocks: an analog modulator and a low-pass digital filter. The main function of the digital filter is to remove the quantization noise introduced by the modulator. This filter determines the frequency response of the transfer function between the output of the ADC and the analog input  $V_{IN}$ . Notice that the frequency axes are normalized to one elementary conversion period  $OSR / f_s$ . The plots of Figure 21 also show that the frequency response changes with the number of elementary conversions  $N_{ELCONV}$  performed. In particular, notches appear for  $N_{ELCONV} \geq 2$ . These notches occur at:

$$f_{NOTCH}(i) = \frac{i \cdot f_s}{OSR \cdot N_{ELCONV}} \quad (\text{Hz}) \text{ for } i = 1, 2, \dots, (N_{ELCONV} - 1)$$

**Equation 24**

and are repeated every  $f_s / OSR$ .

Information on the location of these notches is particularly useful when specific frequencies must be filtered out by the acquisition system. This chip has no dedicated 50/60 Hz rejection filtering but some rejection can be achieved by using Equation 24 and setting the appropriate values of  $OSR$ ,  $f_s$  and  $N_{ELCONV}$ .

Examples:

Rejection [Hz]	$f_{NOTCH}$ [Hz]	$f_s$ [kHz]	OSR [-]	$N_{ELCONV}$ [-]
60	61	125	1024	2
	61	250	1024	4
	61	500	1024	8
50	53	62.5	1024	8
	46	62.5	1024	4
	46	125	1024	8

**Table 32 - 60/50 Hz Line Rejection Examples**

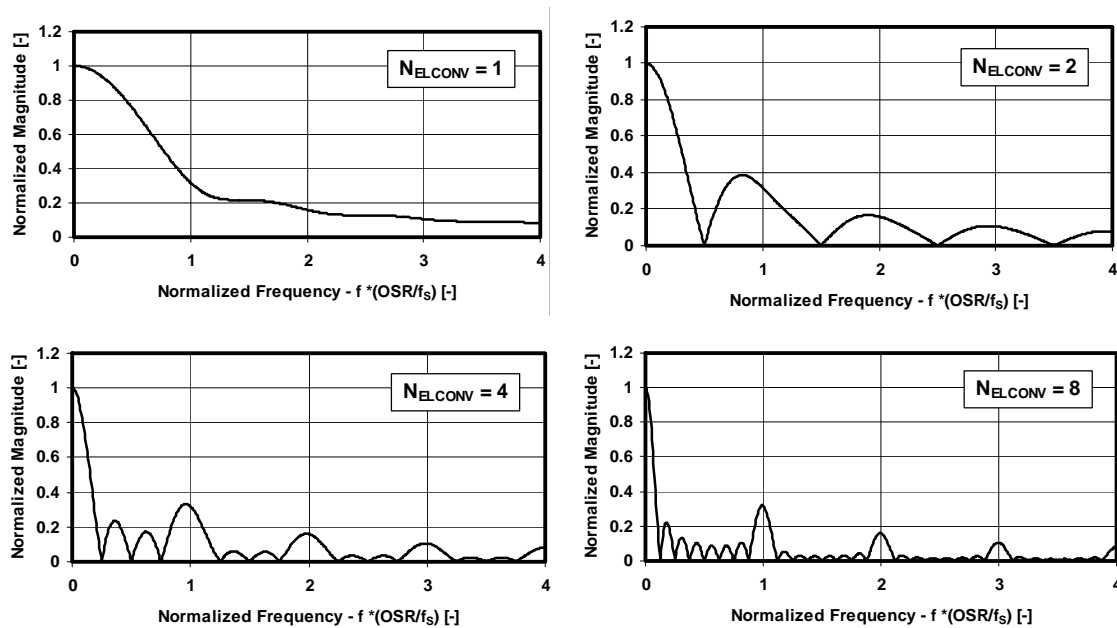

**Figure 21 - Frequency Response: Normalized Magnitude vs. Frequency for Different  $N_{ELCONV}$**

### Power Reduction

The ZoomingADC™ is particularly well suited for low-power applications. When very low power consumption is of primary concern, such as in battery operated systems, several parameters can be used to reduce power consumption as follows:

1. Operate the acquisition chain with a reduced supply voltage VDD.
2. Disable the PGAs which are not used during analog-to-digital conversion with ENABLE[3:0].
3. Disable all PGAs and the ADC when the system is idle and no conversion is performed.
4. Use lower bias currents in the PGAs and the ADC using the control words IB\_AMP\_PGA[1:0] and IB\_AMP\_ADC[1:0].
5. Reduce sampling frequency.

Finally, remember that power reduction is typically traded off with reduced linearity, larger noise and slower maximum sampling speed.

### Recommended Design for Other I2C Devices Connection

SX8724 does not support multiple devices on the same I2C bus. A separate I2C bus should be used to address other devices as seen on the following schematic.

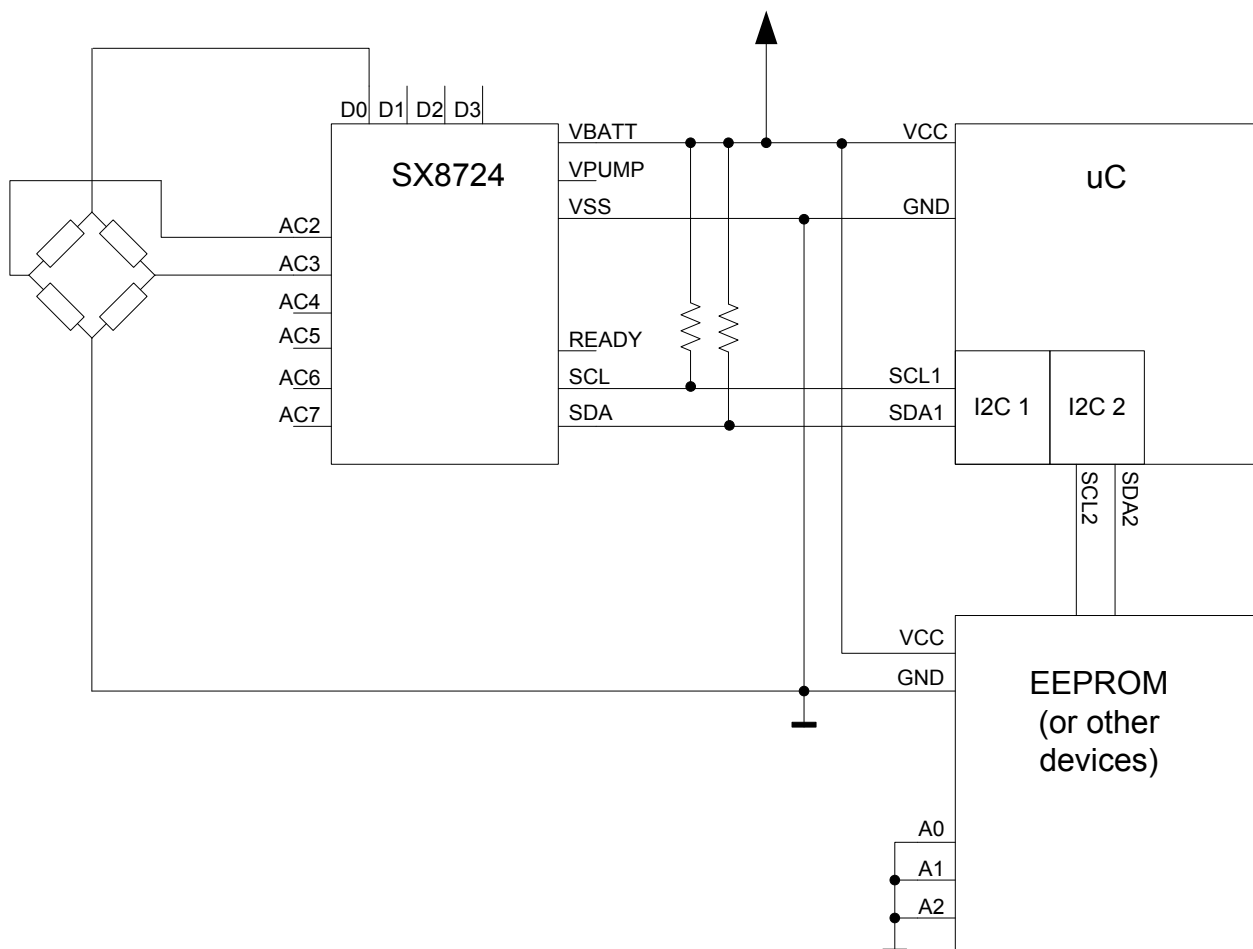

**Figure 22 - Recommended connections with other devices**

## Typical Performance

**Note:** The graphs and tables provided following this note are statistical summary based on limited number of samples and are provided for informational purposes only. The performance characteristics listed herein are not tested or guaranteed. In some graphs or tables, the data presented may be outside the specified operating range and therefore outside the warranted range.

### Linearity

#### Integral Non-Linearity

The different PGA stages have been designed to find the best compromise between the noise performance, the integral non-linearity and the power consumption. To obtain this, the first stage has the best noise performance and the third stage the best linearity performance. For large input signals (small PGA gains, i.e. up to about 50), the noise added by the PGA is very small with respect to the input signal and the second and third stage of the PGA should be used to get the best linearity. For small input signals (large gains, i.e. above 50), the noise level in the PGA is important and the first stage of the PGA should be used.

The following figures show the Integral non linearity for different gain settings over the chip temperature range.

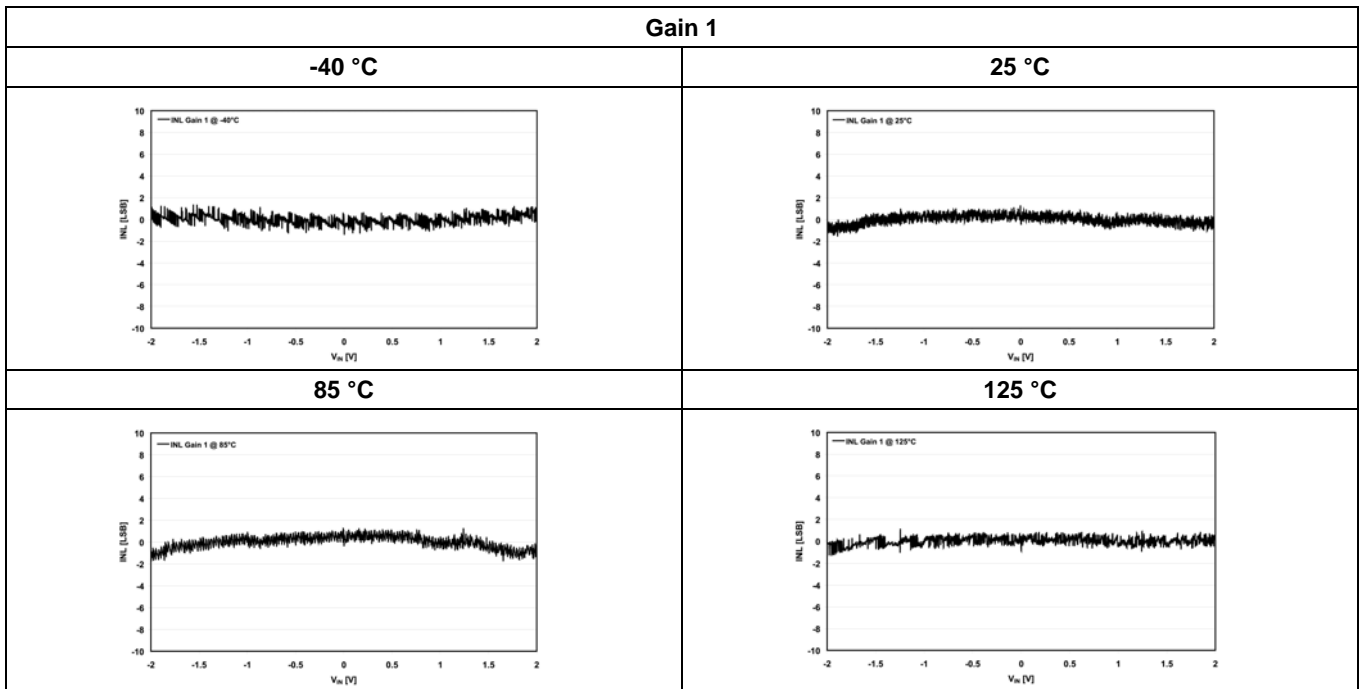



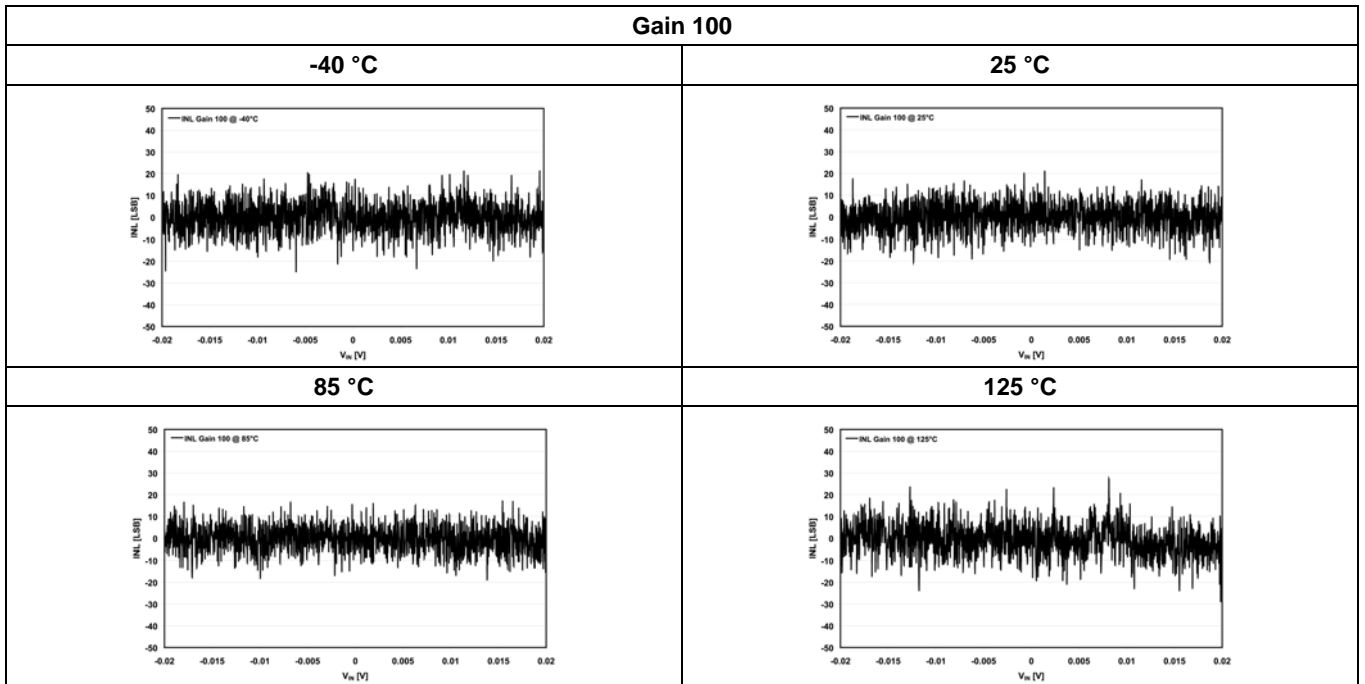
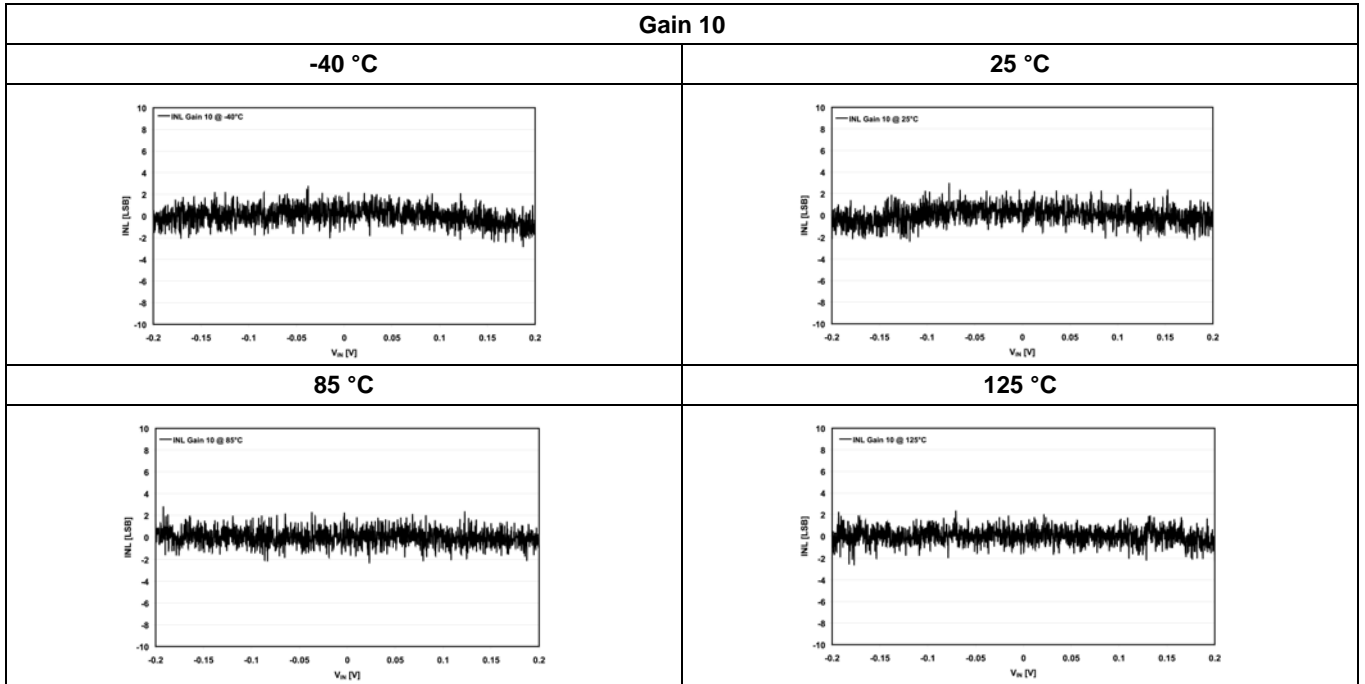

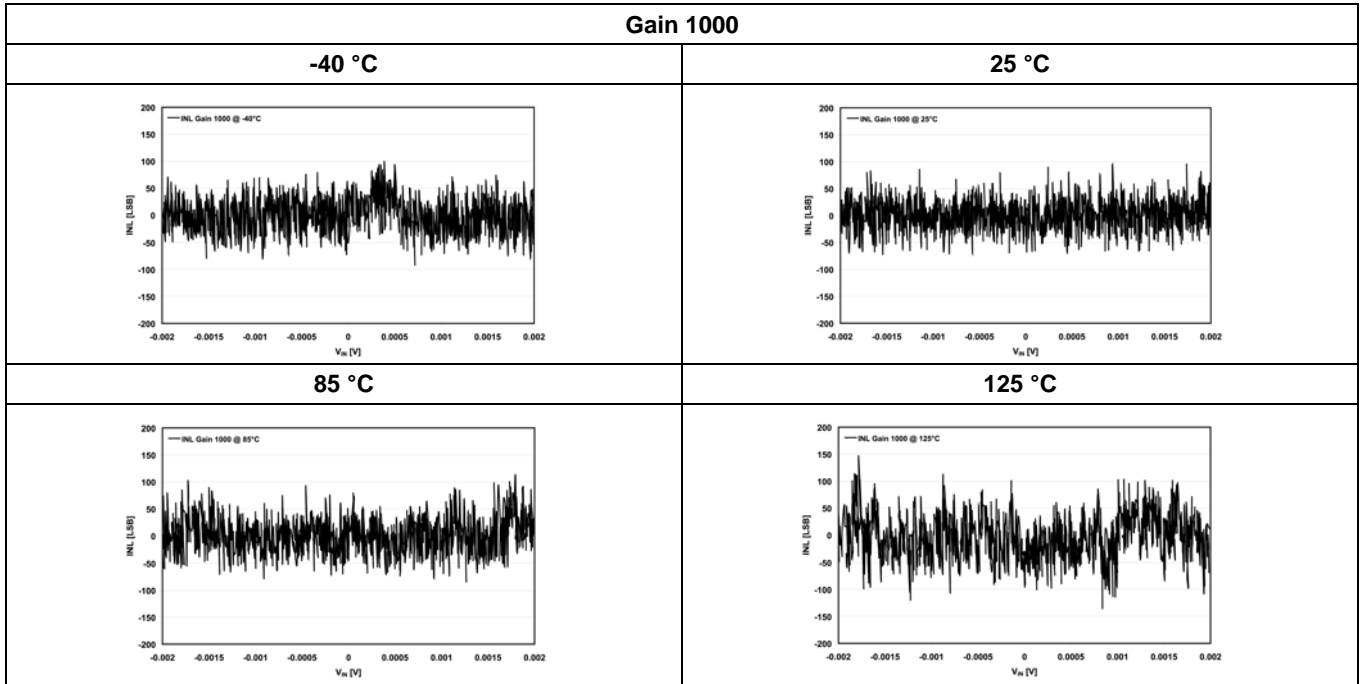

### Differential Non-Linearity

The differential non-linearity is generated by the ADC. The PGA does not add differential non-linearity. Figure 23 shows the differential non-linearity.

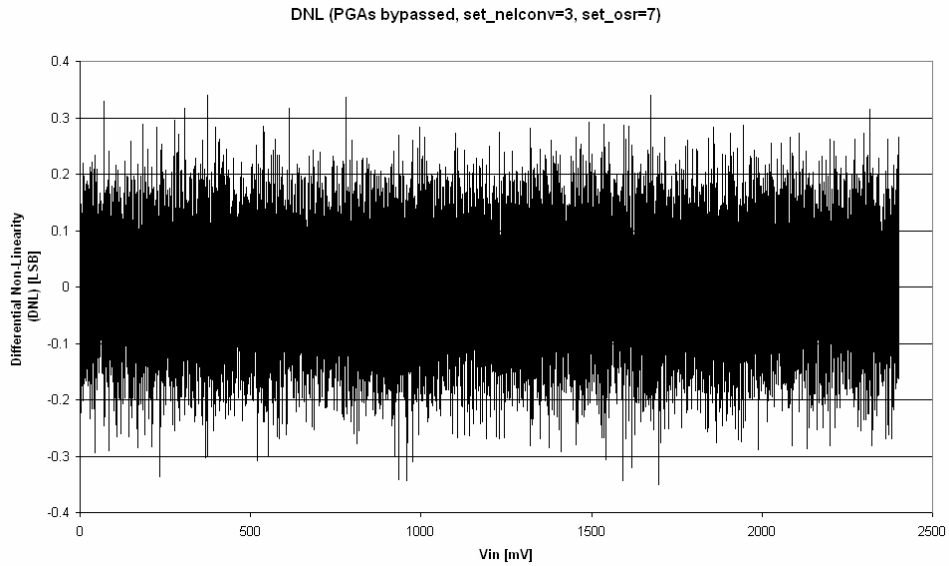

**Figure 23 - Differential Non-Linearity of the ADC Converter**

### Noise

Ideally, a constant input voltage  $V_{IN}$  should result in a constant output code. However, because of circuit noise, the output code may vary for a fixed input voltage. Thus, a statistical analysis on the output code of 1200 conversions for a constant input voltage was performed to derive the equivalent noise levels of PGA1, PGA2, and PGA3. The extracted rms output noise of PGA1, 2, and 3 are given in Table 33: standard output deviation and output rms noise voltage. Figure 24 shows the distribution for the ADC alone (PGA1, 2, and 3 bypassed). Quantization noise is dominant in this case, and, thus, the ADC thermal noise is below 16 bits.

The simple noise model of Figure 25 is used to estimate the equivalent input referred rms noise  $V_{N,IN}$  of the acquisition chain in the model of Figure 26. This is given by the relationship:

$$V_{N,IN}^2 = \frac{\left(\frac{V_{N1}}{GD_1}\right)^2 + \left(\frac{V_{N2}}{GD_1 \cdot GD_2}\right)^2 + \left(\frac{V_{N3}}{GD_1 \cdot GD_2 \cdot GD_3}\right)^2}{(OSR \cdot N_{ELCONV})} \quad (V^2_{rms})$$

**Equation 25**

where  $V_{N1}$ ,  $V_{N2}$ , and  $V_{N3}$  are the output rms noise figures of Table 33,  $GD_1$ ,  $GD_2$ , and  $GD_3$  are the PGA gains of stages 1 to 3 respectively. As shown in this equation, noise can be reduced by increasing  $OSR$  and  $N_{ELCONV}$  (increases the ADC averaging effect, but reduces noise).

Parameter	PGA1	PGA2	PGA3
Standard deviation at ADC output (LSB)	0.85	1.4	1.5
Output rms noise ( $\mu V$ )	205 ( $V_{N1}$ )	340 ( $V_{N2}$ )	365 ( $V_{N3}$ )

**Table 33 - PGA Noise Measurements (n = 16 bits, OSR = 512,  $N_{ELCONV} = 2$ ,  $V_{REF} = 5 V$ )**

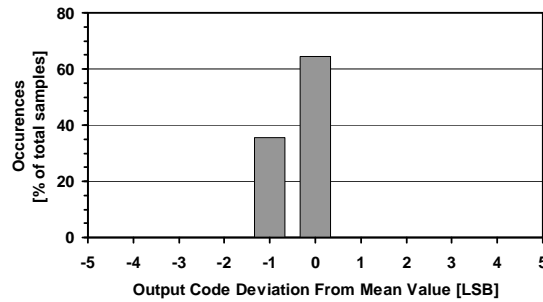

**Figure 24 - ADC Noise (PGA1, 2 & 3 Bypassed, OSR = 512,  $N_{ELCONV} = 2$ )**

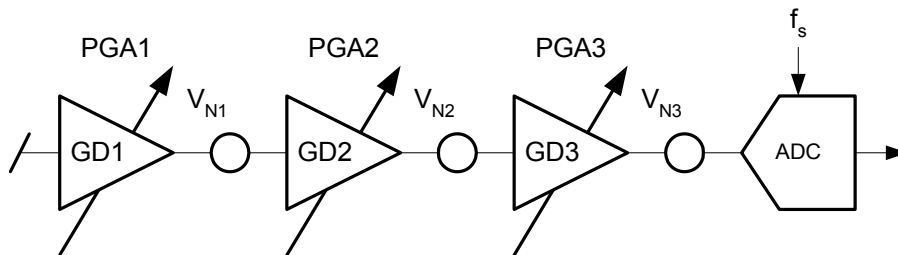

**Figure 25 - Simple Noise Model for PGAs and ADC**

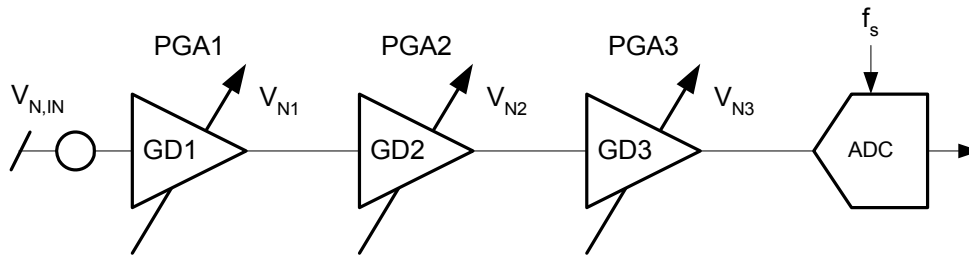

**Figure 26 - Total Input Referred Noise**

As an example, consider the system where:  $GD_2 = 10$  ( $GD_1 = 1$ ; PGA3 bypassed),  $OSR = 512$ ,  $N_{ELCONV} = 2$ ,  $V_{REF} = 5\text{ V}$ . In this case, the noise contribution  $V_{N1}$  of PGA1 is dominant over that of PGA2. Using Equation 25, we get:  $V_{N,IN} = 6.4\ \mu\text{V}$  (rms) at the input of the acquisition chain, or, equivalently, 0.85 LSB at the output of the ADC. Considering 0.2 V (rms) maximum signal amplitude, the signal-to-noise ratio is 90dB.

Noise can also be reduced by implementing a software filter. By making an average on a number of subsequent measurements, the apparent noise is reduced the square root of the number of measurement used to make the average.

### Gain Error and Offset Error

Gain error is defined as the amount of deviation between the ideal transfer function (theoretical Equation 18) and the measured transfer function (with the offset error removed).

The actual gain of the different stages can vary depending on the fabrication tolerances of the different elements. Although these tolerances are specified to a maximum of  $\pm 3\%$ , they will be most of the time around  $\pm 0.5\%$ . Moreover, the tolerances between the different stages are not correlated and the probability to get the maximal error in the same direction in all stages is very low. Finally, these gain errors can be calibrated by the software at the same time with the gain errors of the sensor for instance.

Figure 27 shows gain error drift vs. temperature for different PGA gains. The curves are expressed in % of Full-Scale Range (FSR) normalized to 25°C.

Offset error is defined as the output code error for a zero volt input (ideally, output code = 0). The offset of the ADC and the PGA1 stage are completely suppressed if  $NELCONV > 1$ .

The measured offset drift vs. temperature curves for different PGA gains are depicted in Figure 28. The output offset error, expressed in LSB for 16-bit setting, is normalized to 25°C. Notice that if the ADC is used alone, the output offset error is below  $\pm 1$  LSB and has no drift.

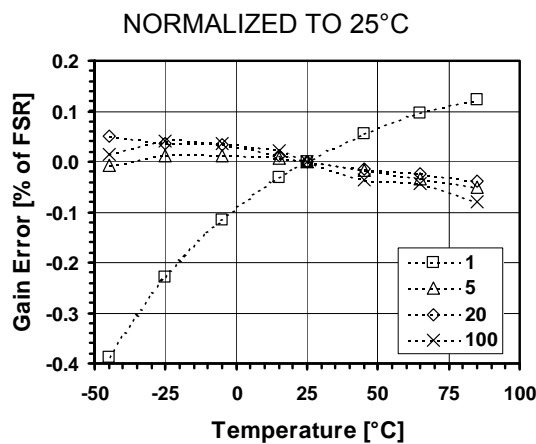

**Figure 27 - Gain Error vs. Temperature for Different PGA Gains**

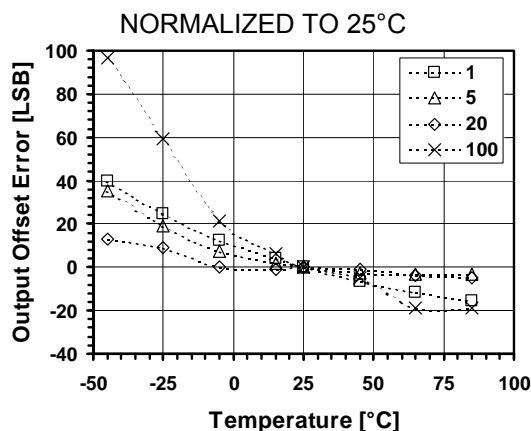
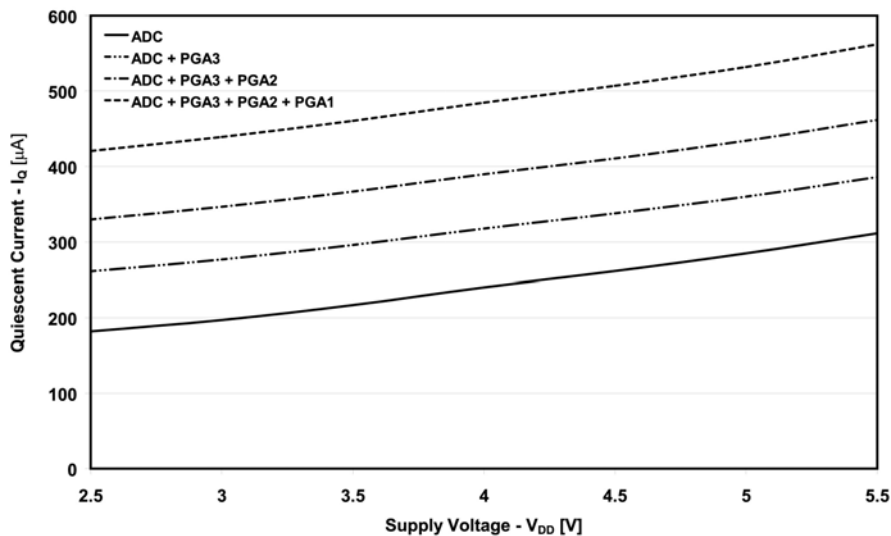

**Figure 28 - Offset Error vs. Temperature for Different PGA Gains**

### Power Consumption

Figure 29 plots the variation of quiescent current consumption with supply voltage  $V_{DD}$ , as well as the distribution between the 3 PGA stages and the ADC (see Table 34). As shown in Figure 30, if lower sampling frequency is used, the quiescent current consumption can be lowered by reducing the bias currents of the PGAs and the ADC with registers `IB_AMP_PGA [1:0]` and `IB_AMP_ADC [1:0]`. (In Figure 30, `IB_AMP_PGA/ADC[1:0]` = '11', '10', '00' for  $f_s = 500, 250, 62.5$  kHz respectively.)

Quiescent current consumption vs. temperature is depicted in Figure 31, showing a relative increase of nearly 40% between  $-45$  and  $+85^\circ\text{C}$ .



**Figure 29 - Quiescent Current Consumption vs. Supply Voltage**

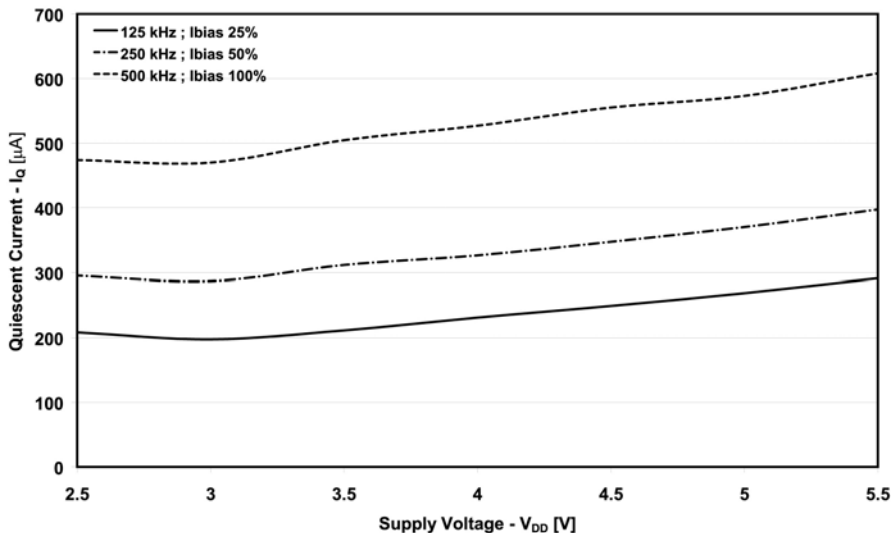

**Figure 30 - Quiescent Current Consumption vs. Supply Voltage for Different Sampling Frequencies**

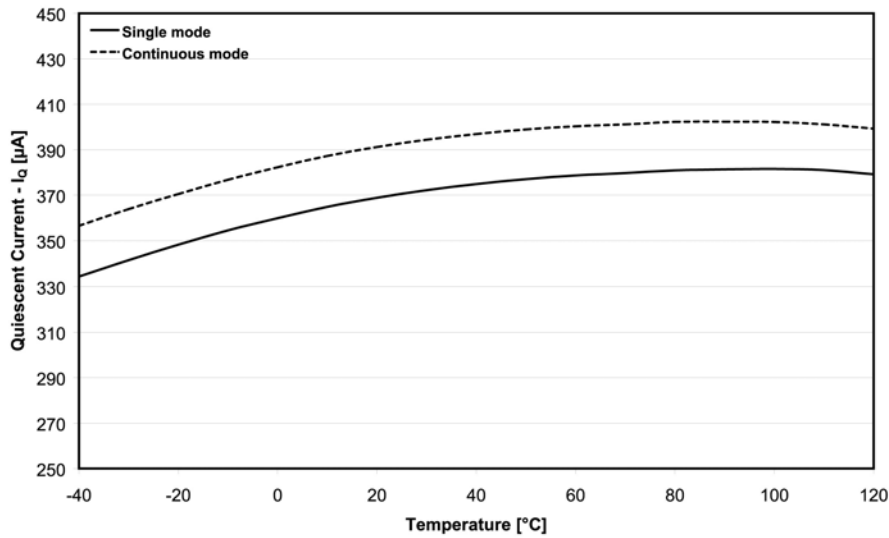
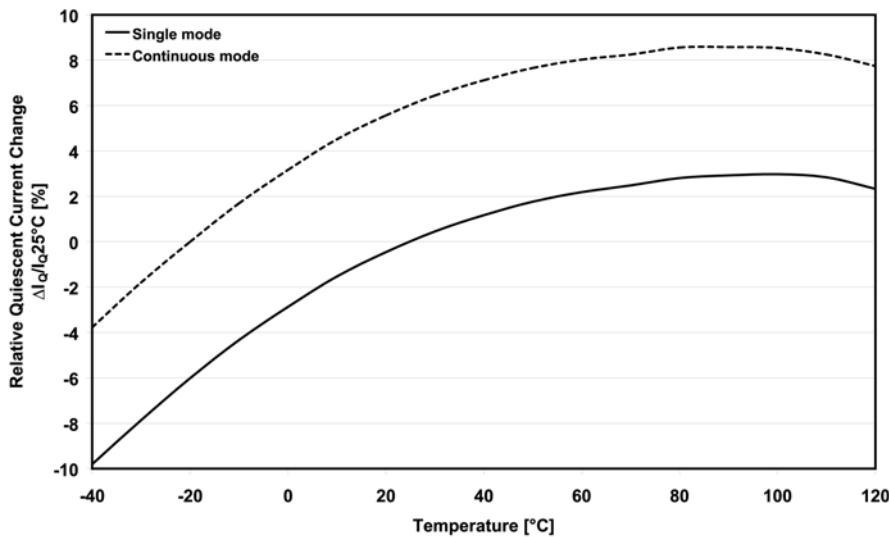
**Figure 31 - Absolute Change in Quiescent Current Consumption vs. Temperature**

**Figure 32 - Relative Change in Quiescent Current Consumption vs. Temperature**

Supply	Back Bone	ADC	PGA1	PGA2	PGA3	TOTAL	Unit
V <sub>DD</sub> = 5 V	142	127	96	86	97	548	µA
V <sub>DD</sub> = 3.3 V	98	105	87	73	96	459	
V <sub>DD</sub> = 2.5 V	99	105	87	71	91	453	

**Table 34 - Typical Quiescent Current Distributions in Acquisition Chain (n = 16 bits, f<sub>s</sub> = 250 kHz)**



### **PCB Layout Considerations**

PCB layout considerations to be taken when using the SX8724 are relatively simple to get the highest performances out of the ZoomingADC. The most important to achieve good performances out the ZoomingADC is to have a good voltage reference. The SX8724 has already an internal reference that is good enough to get the best performances with a minimal amount of external components, but, in case an external reference is needed this one must be as clean as possible in order to get the desired performance. Separating the digital from the analog lines will be also a good choice to reduce the noise induced by the digital lines. It is also advised to have separated ground planes for digital and analog signals with the shortest return path, as well as making the power supply lines as wider as possible and to have good decoupling capacitors.

### **How to Evaluate**

For evaluation purposes XE8000EV121 evaluation kit can be ordered. This kit connects to any PC using a USB port. The "SX87xx Evaluation Tools" software gives the user the ability to control the SX8724 registers as well as getting the raw data from the ZoomingADC and displaying it on the "Graphical User interface". For more information please look at SEMTECH web site (<http://www.semtech.com>).

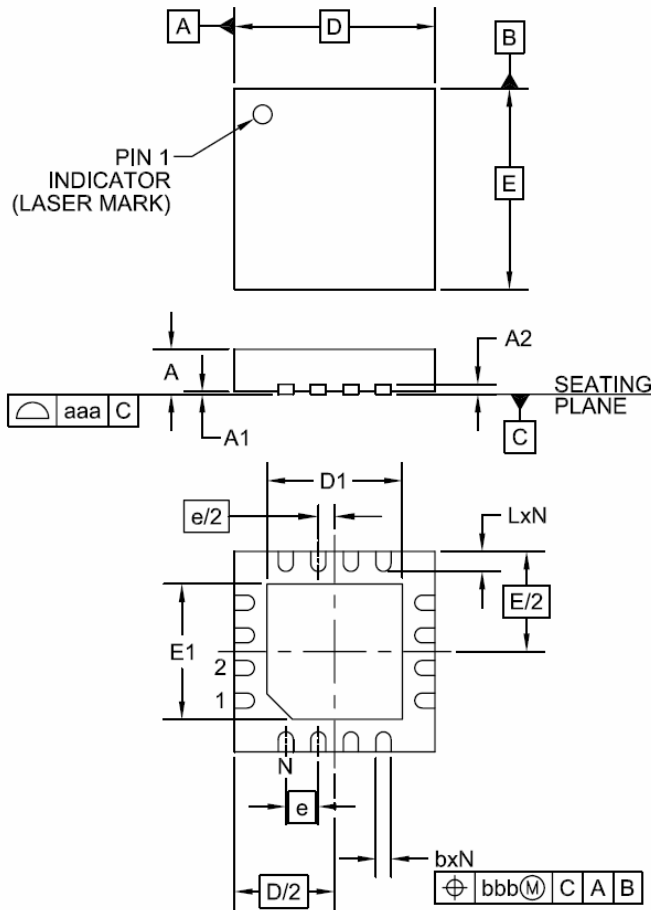
**Package Outline Drawing: MLPQ-16 4x4**

DIM	INCHES			MILLIMETERS		
	MIN	NOM	MAX	MIN	NOM	MAX
A	.031	-	.040	0.80	-	1.00
A1	.000	-	.002	0.00	-	0.05
A2	-	(.008)	-	-	(0.20)	-
b	.010	.012	.014	0.25	0.30	0.35
D	.153	.157	.161	3.90	4.00	4.10
D1	.100	.106	.110	2.55	2.70	2.80
E	.153	.157	.161	3.90	4.00	4.10
E1	.100	.106	.110	2.55	2.70	2.80
e	.026 BSC			0.65 BSC		
L	.012	.016	.020	0.30	0.40	0.50
N	16			16		
aaa	.003			0.08		
bbb	.004			0.10		

**NOTES:**

1. CONTROLLING DIMENSIONS ARE IN MILLIMETERS (ANGLES IN DEGREES).
2. COPLANARITY APPLIES TO THE EXPOSED PAD AS WELL AS THE TERMINALS.
3. DAP IS 2.9 x 2.9 mm

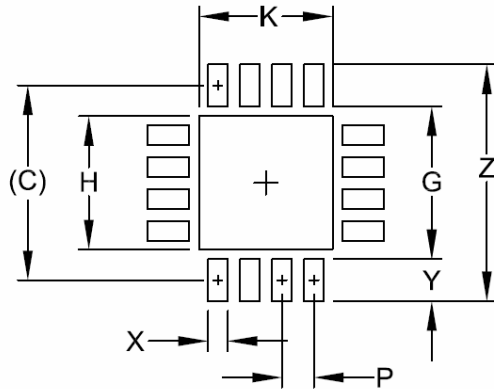
**Land Pattern Drawing: MLPQ-16 4x4**

DIMENSIONS		
DIM	INCHES	MILLIMETERS
C	(.156)	(3.95)
G	.122	3.10
H	.106	2.70
K	.106	2.70
P	.026	0.65
X	.016	0.40
Y	.033	0.85
Z	.189	4.80

**NOTES:**

1. CONTROLLING DIMENSIONS ARE IN MILLIMETERS (ANGLES IN DEGREES).
2. THIS LAND PATTERN IS FOR REFERENCE PURPOSES ONLY. CONSULT YOUR MANUFACTURING GROUP TO ENSURE YOUR COMPANY'S MANUFACTURING GUIDELINES ARE MET.
3. THERMAL VIAS IN THE LAND PATTERN OF THE EXPOSED PAD SHALL BE CONNECTED TO A SYSTEM GROUND PLANE. FAILURE TO DO SO MAY COMPROMISE THE THERMAL AND/OR FUNCTIONAL PERFORMANCE OF THE DEVICE.
4. SQUARE PACKAGE - DIMENSIONS APPLY IN BOTH " X " AND " Y " DIRECTIONS.

### Tape and Reel Specification

MLP/QFN (0.70mm - 1.00mm package thickness)

1. Single Sprocket holes
2. Tolerances for Ao & Bo are +/- 0.20mm
3. Tolerances for Ko is +/- 0.10mm
4. Tolerance for Pocket Pitch is +/- 0.10mm
5. Tolerance for Tape width is +/-0.30mm
6. Trailer and Leader Length are minimum required length
7. Package Orientation and Feed Direction

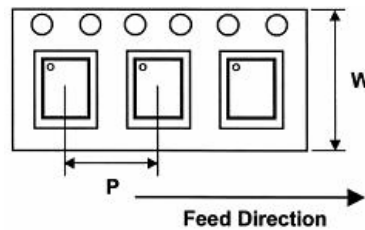

### 8. Tape and Reel Dimensions

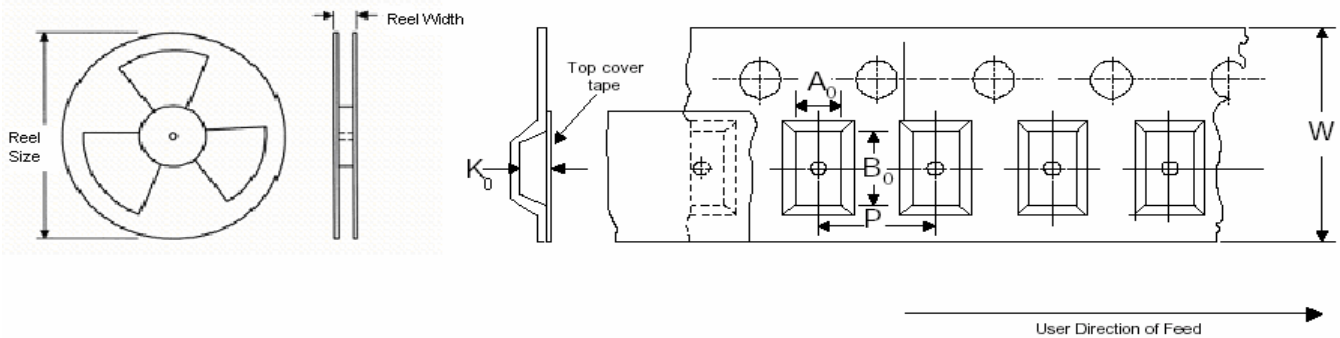

Pkg size	carrier tape (mm)					Reel		Trailer Length (mm)	Leader Length (mm)	QTY per Reel
	Tape Width (W)	Pocket Pitch (P)	Ao	Bo	Ko	Reel Size (in)	Reel Width (mm)			
2.0x2.0	8	4	2.25	2.25	1.00	7	8.4	160	400	3000
2.3x2.3	12	8	2.60	2.60	1.00	13	12.4	400	400	3000
3x3	12	8	3.30	3.30	1.10	13	12.4	400	400	3000
4x4	12	8	4.35	4.35	1.10	13	12.4	400	400	3000
4x3	12	8	3.30	4.30	1.10	13	12.4	400	400	3000
5x5	12	8	5.25	5.25	1.10	7/13	12.4	200/400	400	500/3000
6x6	16	12	6.30	6.30	1.10	13	16.4	400	400	3000
6x5	12	8	5.30	6.30	1.10	13	12.4	400	400	3000
7x7	16	12	7.30	7.30	1.10	13	16.4	400	400	3000
9x9	16	12	9.30	9.30	1.10	13	16.4	400	400	3000
10x10	24	16	10.30	10.30	1.10	13	24.4	400	400	3000
11x11	24	16	11.40	11.40	1.20	13	24.4	400	400	3000

© Semtech 2007

All rights reserved. Reproduction in whole or in part is prohibited without the prior written consent of the copyright owner. The information presented in this document does not form part of any quotation or contract, is believed to be accurate and reliable and may be changed without notice. No liability will be accepted by the publisher for any consequence of its use. Publication thereof does not convey nor imply any license under patent or other industrial or intellectual property rights. Semtech assumes no responsibility or liability whatsoever for any failure or unexpected operation resulting from misuse, neglect improper installation, repair or improper handling or unusual physical or electrical stress including, but not limited to, exposure to parameters beyond the specified maximum ratings or operation outside the specified range.

SEMTECH PRODUCTS ARE NOT DESIGNED, INTENDED, AUTHORIZED OR WARRANTED TO BE SUITABLE FOR USE IN LIFE-SUPPORT APPLICATIONS, DEVICES OR SYSTEMS OR OTHER CRITICAL APPLICATIONS. INCLUSION OF SEMTECH PRODUCTS IN SUCH APPLICATIONS IS UNDERSTOOD TO BE UNDERTAKEN SOLELY AT THE CUSTOMER'S OWN RISK. Should a customer purchase or use Semtech products for any such unauthorized application, the customer shall indemnify and hold Semtech and its officers, employees, subsidiaries, affiliates, and distributors harmless against all claims, costs damages and attorney fees which could arise.

#### Contact Information

Semtech Corporation  
Advanced Communication and Sensing Products Division  
200 Flynn Road, Camarillo, CA 93012  
Phone (805) 498-2111 Fax : (805) 498-3804